

FRONT VIEW

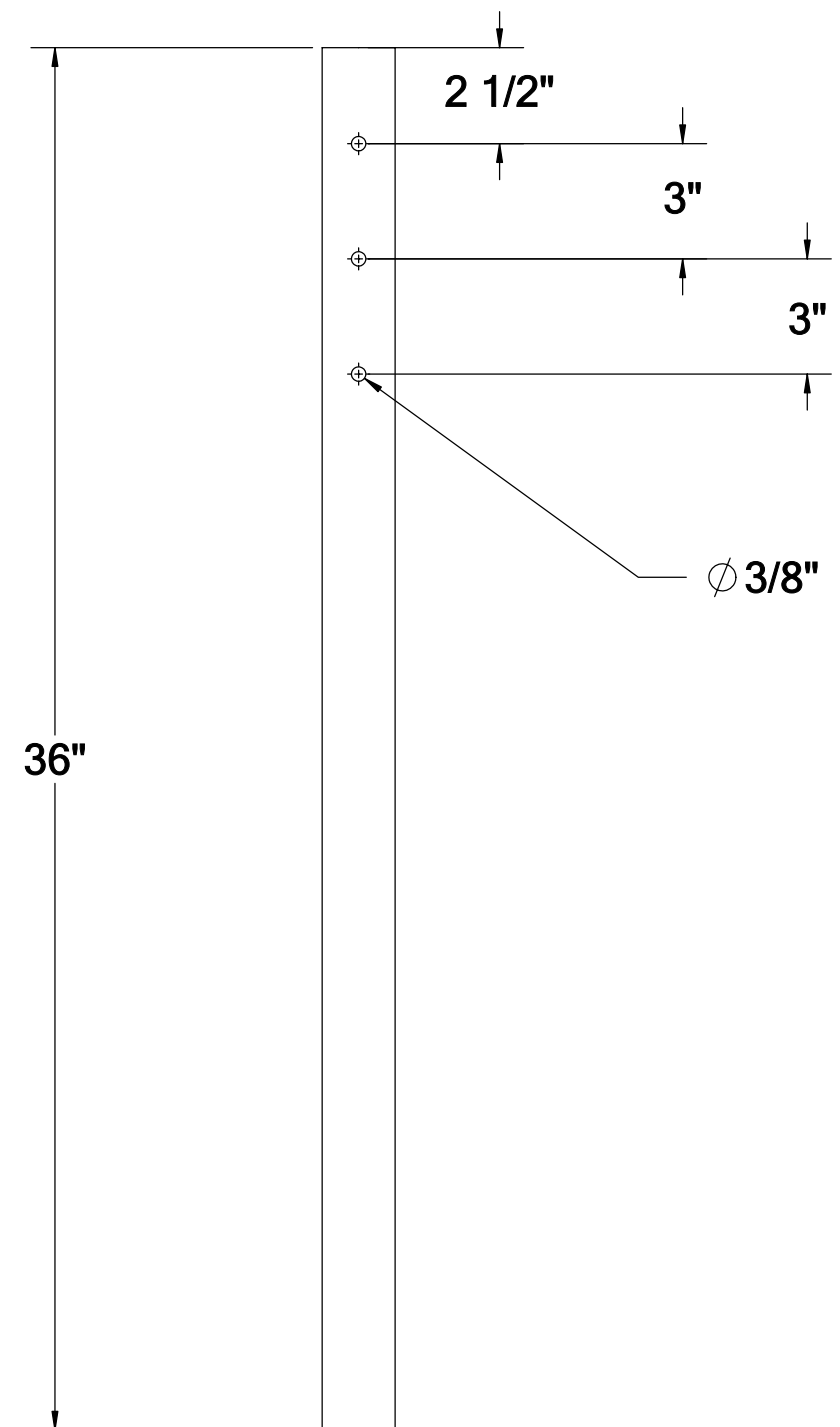

TOP VIEW

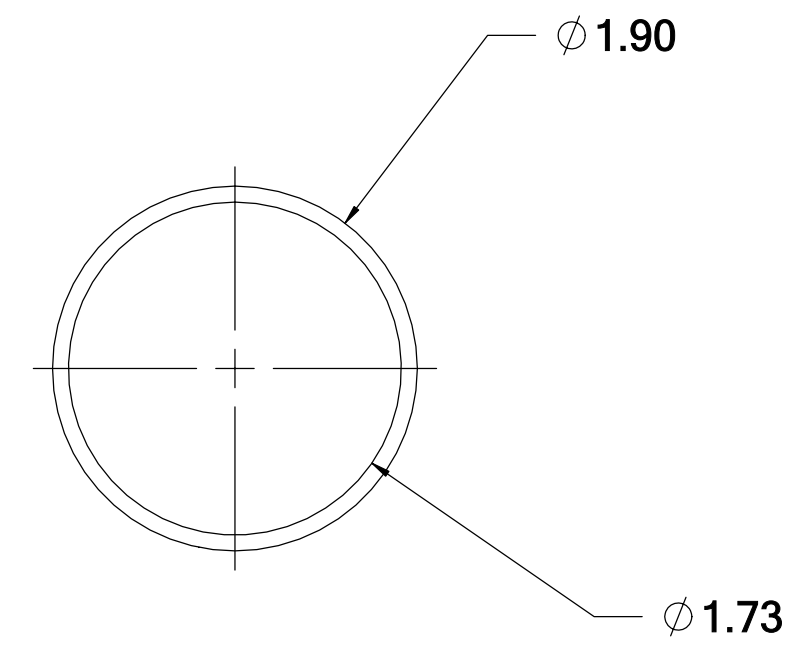

UNLESS OTHERWISE SPECIFIED: DIMENSIONS ARE IN INCHES TOLERANCES: FRACTIONAL $\pm 1/32$ ANGULAR $\pm .5^\circ$ ONE PLACE DECIMAL $\pm .06$ TWO PLACE DECIMAL $\pm .03$ THREE PLACE DECIMAL $\pm .01$		NAME	DATE	PART NUMBER 102675
	DRAWN	TS	1/31/2005	
	CHECKED	JG	1/31/2005	
	ENG APPR.			
GUAGE: 14		Q.A.		PDMWorks Project: GROUND POST Rev. By: CJO Last Rev. Date: 3/27/2006
MATERIAL: GALV.	COMMENTS:			
DO NOT SCALE DRAWING				