

# ONTIME TIMER SPECIFICATION



## Quick Start Guide

**SKU #102719**

Revised: 01.16.2008

Thank you for purchasing the Ontime Timer. This timer enables automatic on and off control of an electronic device such as lights or a fan. When properly connected and maintained, this product will provide years of reliable service. These instructions include helpful hints and important information needed to safely assemble and properly maintain the timer. Please read these instructions **before** you begin.

If you have any questions during the assembly, contact Customer Service at 1-800-245-9881 for assistance.

## SAFETY PRECAUTIONS

If you are not familiar with electrical wiring, consult or hire an electrician and building contractor to mount, assemble, and wire this timer to your electronic device.

## DOCUMENT CONVENTIONS

**NOTE:** Alerts you to important information.

**!CAUTION:** Advises you of precautions to take to avoid bodily injury or product damage.

## UNPACK TIMER KIT AND IDENTIFY PARTS

Unpack the content of your kit where you can easily inventory the parts shown below. If you do not have all the parts, please contact customer service.

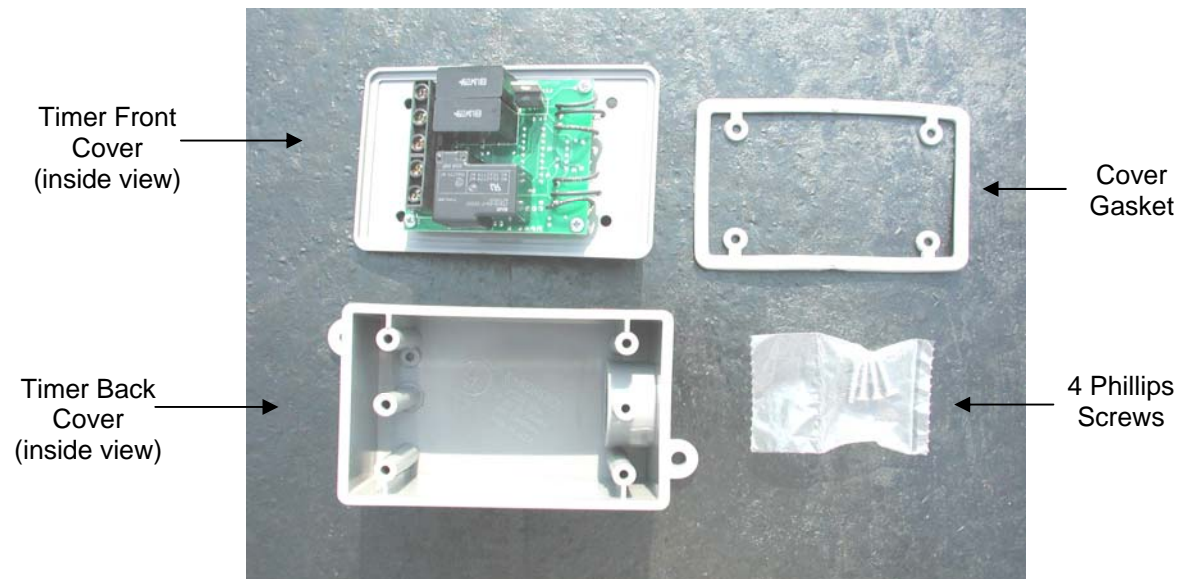

## TOOLS AND ELECTRONIC DEVICE

- Phillips screwdriver
- Wire or power cord cutters
- Electronic device, such as fan or heater, to connect to timer
- Timer kit
- 2 mounting anchors or screws (for mounting timer)—supplied by customer.

## MOUNTING THE TIMER

This timer must be properly mounted *before* connecting an electronic device to it. (Mounting screws are not included in the timer kit and must be supplied by the customer.)

**!CAUTION:** Improper mounting of timer device could result in bodily injury or damage to the timer or the electronic device attached to it. If you have little or no experience in electrical wiring, you must consult or hire an electrician and verify local building codes *before* mounting the timer.

1. Place the timer back cover on the surface where you want it permanently mounted.
2. Mark the mounting surface where the anchor or screw holes will be drilled.
3. Drill the marked screw or anchor holes (if needed). This step depends on the type of fastener and the mounting surface.
4. Position the timer over the drilled holes or fasteners.
5. Insert the screws into the predrilled screw holes (if applicable).
6. Tighten the anchors or screws to secure the back cover.

## CONNECTING AN ELECTRONIC DEVICE TO THE TIMER

*This procedure is only for the most common application of connecting the timer to an electronic device such as a fan or heater. You may choose to wire the device to a different electronic device; if so, the wiring may need to be different than this procedure instructs. Contact a qualified professional experienced with wiring the device you plan to operate using the timer.*

**NOTE:** This timer model is designed to be *hardwired* to an electronic device and power source. The timer is positioned between the power source and electronic device.

### Preparing the Electronic Device

**!CAUTION:** Make sure that your electronic device (e.g., fan or lights) is disconnected from its power source before following this procedure. If you cannot easily identify the different wires and/or have never hardwired an electronic device, *consult or hire an electrician to wire the timer to your electronic device. Check local codes. Some areas require a professional contractor to complete electrical improvements and alterations.*

1. Disconnect the power from the electrical device (e.g., fan or lights) that will be controlled by the timer.
2. Using wire cutters or a similar tool, cut the power cord in half in the spot where you want to install the timer.
3. Strip 6 to 12 inches of the outer insulation from the power cord on both sides of the split to expose the wires.

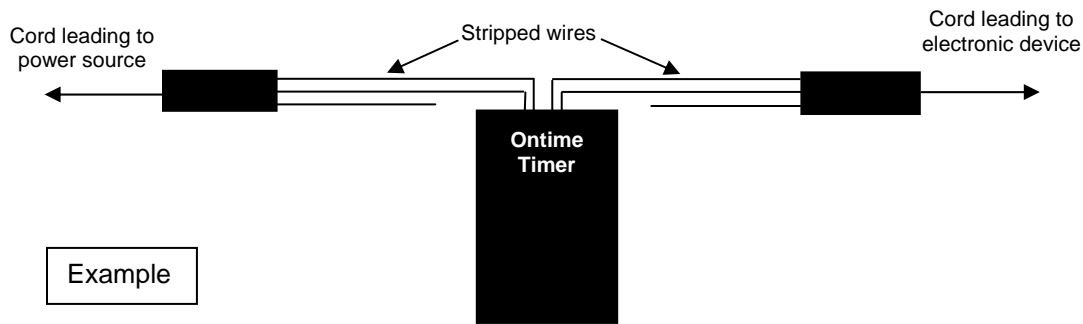

4. Identify the common (or neutral) and the power (or hot) wires in the power cord.

### CONNECTING A 120V DEVICE TO THE 102719 TIMER

**NOTE:** If you have a 220V electronic device, see *Connecting a 220V Electronic Device to the Timer*.

1. On the inside front cover of the timer, loosen the NEUT, L1, and NO wire connectors.

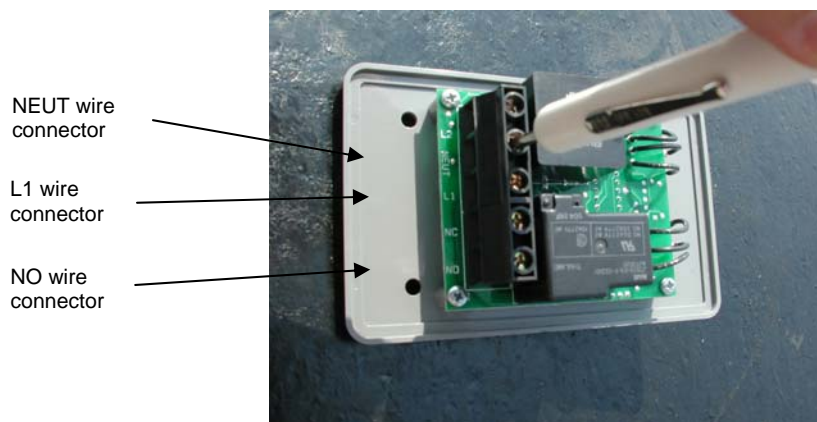

SEE THE WIRING  
DIAGRAM ON  
THE NEXT PAGE  
FOR 120V  
APPLICATIONS.

2. Position the cover gasket over the inside edge of the timer's back cover.

**! CAUTION:** Inserting incorrect wires into the incorrect wire connectors may result in damage to your electronic device or timer. *Consult or hire an electrician if needed to install the timer.*

3. Using the wire diagram given in Figure 1 (next page), follow these steps:
  - a) Insert the power source and electronic device neutral (or common) wires through the timer back cover and then into the timer NEUT wire connector. Tighten the wire connector screw over the wires using a Phillips screwdriver.
  - b) Insert the power source Power (or hot) Wire #1 through the timer back cover and then into the timer L1 wire connector. Tighten the wire connector.
  - c) Insert the electronic device Power (or hot) Wire #1 through the timer back cover and then into the timer NO wire connector. Tighten the wire connector.

**NOTE:** The relay switches L1 to the NO and NC outputs.

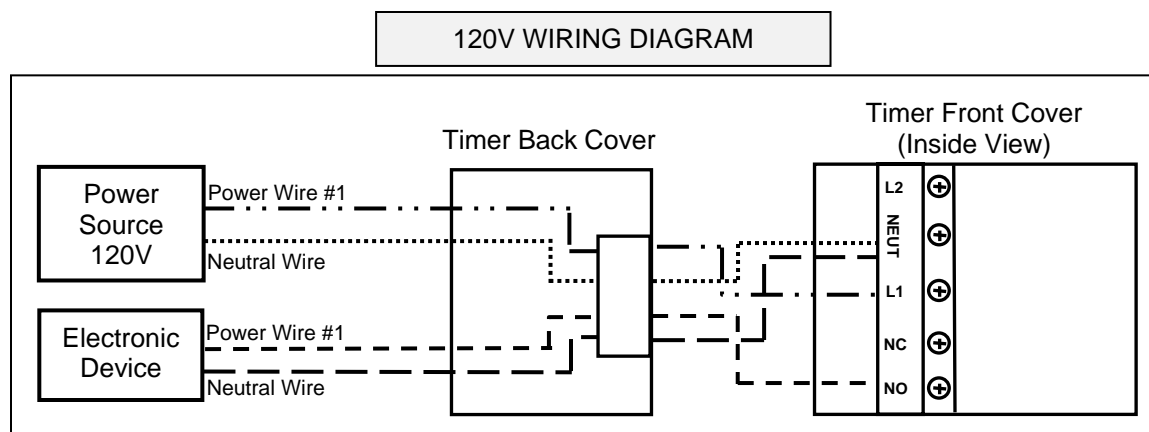
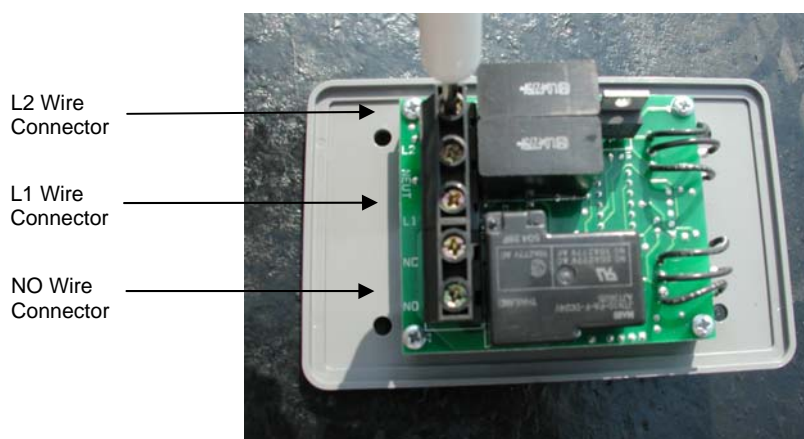

Figure 1. 120V Wire Diagram

### CONNECTING A 220V (240V) DEVICE TO THE 102719 TIMER

**NOTE:** If you have a 120V electronic device, see *Connecting a 120V Electronic Device to Timer*.

1. On the inside front cover of the timer, loosen the L2, L1, and NO wire connector screws.



SEE THE WIRING DIAGRAM ON THE NEXT PAGE FOR 220V (240V) APPLICATIONS.

2. Position the cover gasket over the inside edge of the timer back cover.

**!CAUTION:** Inserting incorrect wires into the wire connectors may result in damage to your electronic device or timer. *Consult or hire an electrician if needed to install the timer.*

3. Using the wire diagram given in Figure 2 (next page), follow these steps:
  - a) Insert the power source and electronic device Power (or hot) Wire #2 through the timer back cover and then into the timer L2 wire connector. Tighten the wire connector using a Phillips screwdriver.
  - b) Insert the power source Power (or hot) Wire #1 through the timer back cover and then into the timer L1 wire connector. Tighten the wire connector.
  - c) Insert the electronic device Power (or hot) Wire #1 through the timer back cover and then into the timer NO wire connector. Tighten the wire connector.

**NOTE:** The relay switches L1 to the NO and NC outputs.

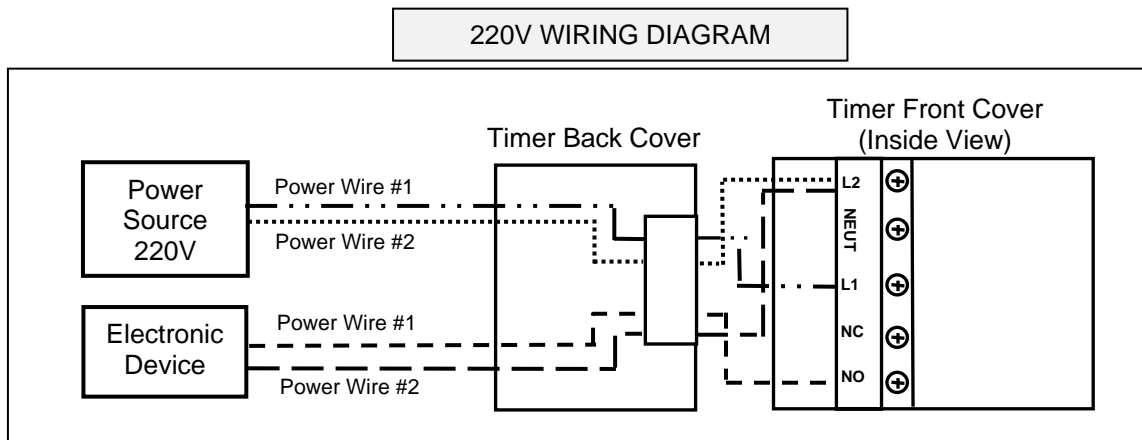

Figure 2. 220V Wire Diagram

## OPERATING THE TIMER

**NOTE:** From the factory, the timer will power up in the off state (no LEDs lit). If a loss of power occurs, the timer will power up in the state it was in when the power loss occurred.

### Setting the Mode

1. On the front panel of timer, turn both knobs to MIN (full counter-clockwise position) and apply power.

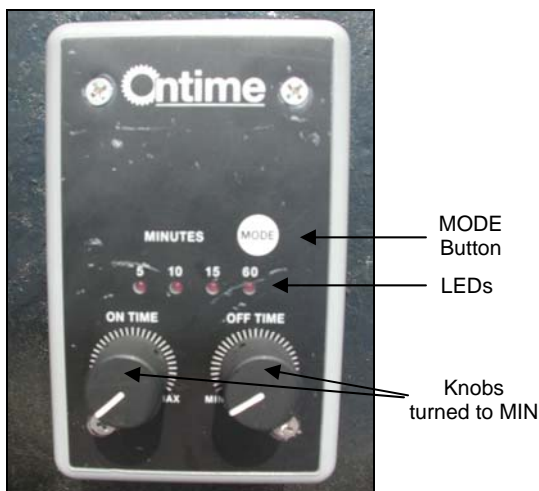

**ATTENTION:** The first five (5) hash marks for each of the timing controls are used at the factory for calibration purposes only.

*These marks do not control any timing for your device.*

All timing for your device will begin using the sixth (6<sup>th</sup>) mark on each control.

2. Press the MODE button once. The MODE 5 LED will light.
3. Continue pressing the MODE button to change the timer mode to 10, 15, or 60.

**EXAMPLE:** If you rotate both knobs to MAX in MODE 5, the timer cycles at *approximately 5 minutes* powered on and *approximately 5 minutes* powered off. See the table below for *approximate times*:

Timer Mode	Time On Cycle	Time Off Cycle
5	5 minutes	5 minutes
10	10 minutes	10 minutes
15	15 minutes	15 minutes
60	60 minutes	60 minutes

**NOTE:** To return the timer to the off mode from MODE 60, press the MODE button once, or continue pressing MODE button until all of the LEDS are no longer lit.

### Setting the On-Off Cycling Modes

To set the power on-off cycles to timed cycles different than the preset cycling modes indicated in the *Setting the Mode* section, follow these steps:

1. Press the MODE button to set an *approximate* 5-, 10-, 15-, or 60-minute timing mode. For details, see *Setting the Mode* section.
2. Turn the ON TIME knob to the desired power-on timing mark. See the table below for approximate time increments for MODE 5, 10, 15 or 60 set in Step 1.

**NOTE:** *There are 30 hash marks for each timer control knob: 25 are active hash marks and 5 are inactive.* (The first 5 are *inactive* and are used for factory calibration purposes only.) As you change the mode, the seconds per hash mark change too. For example, in Mode 5, marks 6-30 regulate time in 10-second intervals. In Mode 10, marks 6-30 regulate time in 20-second intervals. See the table below for the remaining modes.

MODE	Seconds per Hash Mark (marks 6-30)
5	10
10	20
15	30
60	120

3. Turn the OFF TIME knob to the desired powered off time increment using the table on the previous page.

**NOTE:** The electronic device now powers on and off at the time increments set by the MODE button and ON TIME and OFF TIME knobs cycling between the two until you power off the device or set the increments and/or mode to another setting. See the example below for clarification.

*Example:* Set the timer to MODE 5, where the "5" LED is lit. Rotate the ON TIME knob to the 7<sup>th</sup> hash mark. (REMEMBER: MARKS 1-5 ARE INACTIVE.) Rotate the OFF TIME knob to the 8<sup>th</sup> hash mark. (REMEMBER: MARKS 1-5 ARE INACTIVE.) Your electronic device will now power on for approximately 20 seconds (10 seconds x 2 marks = 20 seconds) and will power off for 30 seconds (10 seconds x 3 marks = 30 seconds), cycling between the two until you power off the timer, the device, or change the timer increments and/or mode.

### Setting the Continuous On Mode

To leave the electronic device powered on continuously, follow these steps:

1. Turn the OFF TIME knob to MIN.
2. Turn the ON TIME knob until you hear a click.

The unit now remains powered on until the ON TIME knob is turned to MIN or the timer is powered off by pressing the MODE button.

### **Ending the Cycle before Completing the Cycle**

To completely end a cycle before completing its last cycle, follow these steps:

1. Turn both ON TIME and OFF TIME knobs to MIN.
2. Press the MODE button until timer turns off.

### **Ending the Cycle after Completing the Cycle**

To end a cycle after timer has completed its last cycle, turn both ON TIME and OFF TIME knobs to MIN.

### **Testing (or Troubleshooting) the Timer**

If you are having difficulty setting the timer to the desired time increments, follow this suggestion:

- Test the timer using shorter time increment cycles. For example, set the timer to the MODE 5 and then set the ON TIME knob to *the first active hash mark (#6)* and the OFF TIME knob to *the first active hash mark (#6)*. If the timer cycles on and off, then recheck the tables above to make sure you have it set correctly based on the time increments given.

**REMEMBER:** MARKS 1-5 ARE INACTIVE. THEY ARE USED FOR FACTORY CALIBRATION ONLY.

If the timer is not working properly, follow this suggestion:

- Power off the timer, remove the timer front cover, verify the wires are still tight in the wire connectors and that they are in the appropriate wire connectors, replace the front cover, and power on the timer. Repeat the first troubleshooting procedure.