



## GrowSpan<sup>TM</sup> Round Cold Frames



*Photo may show a different but similar model.*

©2023 GrowSpan  
All Rights Reserved. Reproduction  
is prohibited without permission.



WARNING: Cancer and Reproductive Toxicity - P65Warnings.ca.gov

STK#	DIMENSIONS
103106	26' W x 12' H x 24' L
103107	26' W x 12' H x 48' L
102861	26' W x 12' H x 96' L



### YOU MUST READ THIS DOCUMENT BEFORE YOU BEGIN TO ASSEMBLE THE SHELTER.

Thank you for purchasing this Growspan™ Cold Frame. When properly assembled and maintained, this product will provide years of reliable service. These instructions include helpful hints and important information needed to safely assemble and properly maintain the cold frame. Please read these instructions **before** you begin.

If you have any questions during the assembly, contact Customer Service for assistance.

### SAFETY PRECAUTIONS

- Wear eye protection.
- Wear head protection.
- Wear gloves when handling metal parts.
- Use a portable GFCI (Ground Fault Circuit Interrupter) when working with power tools and cords.
- Do not climb on the frame during or after construction.
- Do not occupy the structure during high winds, tornadoes, or hurricanes.
- Provide adequate ventilation if the structure is enclosed.
- Do not store hazardous materials in the structure.
- Provide proper ingress and egress to prevent entrapment.

### LOCATION

Choosing the proper location is an important step before you begin to assemble the structure.

The following suggestions and precautions will help you determine whether your selected location is the best location.

- Never erect the structure under power lines.
- Identify whether underground cables and pipes are present *before* preparing the site or anchoring the structure.
- Location should be away from structures that could cause snow to drift on or around the building.
- Do not position the structure where large loads such as snow and ice, large tree branches, or other overhead obstacles could fall.

### SITE

After choosing a location, proper preparation of the site is essential. Follow the information below.

- *A level site is required.* The site must be level to properly and safely erect and anchor the structure.
- **Drainage:** Water draining off the structure and from areas surrounding the site should drain away from the site to prevent damage to the site, the structure, and contents of the structure.

**⚠ WARNING:** The individuals assembling this structure are responsible for designing and furnishing all temporary bracing, shoring and support needed during the assembly process. For safety reasons, those who are not familiar with recognized construction methods and techniques must seek the help of a qualified contractor.

## ASSEMBLY PROCEDURE

Following the instructions as presented will help ensure the proper assembly of your structure. Failing to follow these steps may result in an improperly assembled and anchored structure and will void all warranty and protection the owner is entitled to.

The steps outlining the assembly process are as follows:

1. Verify that all parts are included in the shipment. Notify Customer Service for questions or concerns.
  2. Read these instructions, and all additional documentation included with the shipment **before** you begin assembling the structure.
  3. Gather the tools, bracing, ladders (or lifts), and assistance needed to assemble the structure.
  4. Check the weather **before** you install the roof cover and any panels (if equipped). Do not install covers or panels on a windy or stormy day.
  5. Re-evaluate the location and site based on the information and precautions presented in the documentation included with the shipment.
  6. Prepare the site (if applicable).
  7. Assemble the frame components in the order they are presented in these instructions.
  8. Properly connect the assembled frame to the ground posts.
  9. Install, tighten, and secure the end panel and main cover (if equipped). This applies to covers that stretch over the frame assembly. Your shelter may include roof panels or side panels or both.
  10. Read the care and maintenance information at the end of these instructions.
  11. Complete and return all warranty information as instructed.
- **Conduit:** An assembly of pipes used to secure the main cover and end panels (if equipped). Purlins and some strut assemblies also consist of connected pipes to form a conduit. Each pipe joint of a conduit assembly is secured with a self-tapping Tek screw.
  - **Coupler or Fitting:** A part of the frame assembly where legs, purlins and rafter pipes are inserted and secured. In most instances, 3-way and 4-way couplers are used. In some larger applications, couplers are used to secure the joints of the different rafter sections during the assembly of the rafters. Some shelters do not use couplers.
  - **Foot or Rafter Foot:** The part attached to and found at the base of the rafter or leg of the shelter. Depending on the shelter, the foot is an optional purchase. Some shelters do not offer an optional foot. Some use 1-way connectors or ground posts.
  - **Must Read Document:** This document includes building and shelter anchoring instructions, steps for end wall reinforcement, safety precautions, and notices and warnings. The Must Read document is sent with all shelters and buildings. If you did not receive a Must Read document, contact Customer Service to request one.
  - **On-Center:** Term used to describe a measurement taken from the vertical center of the rafter or frame member to the vertical center of another.
  - **Purlin:** The pipe assembly that runs perpendicular to the rafters or framework that supports the main cover. Purlins are found on the sides and roof areas of the assembled frame, are evenly spaced, and typically run from the front to the back of the shelter.
  - **Plain or Straight Pipe:** A term used to describe a pipe that has the same diameter or width throughout its entire length.
  - **Strut:** A strut is usually a length of pipe with two flattened ends and is used for diagonal bracing of the shelter frame. A strut is typically secured to the frame work by special brackets and bolts.
  - **Swaged End or Swaged Pipe:** The term “swaged” refers to the tapered end of the pipe or tube. Swaged ends of a pipe can be inserted into couplers and the straight ends of other pipes.
  - **Tek Screw:** A self-tapping fastener used to secure pipe joints and to fasten brackets to rafters.

## LIST OF WORDS AND PHRASES

Before you begin, it is important to become familiar with the words and phrases used in this instruction manual.

These words and phrases are common to most Growspan™ shelters and identify the different parts of the shelter. (Some are used in this document. Others may not apply to this particular shelter.) These terms describe the shipped parts and can also be found on the materials list/spec sheets included with the shipment. To aid in the assembly, read through the following definitions before you begin to assemble your shelter.

## GROWSPAN™ ROUND COLD FRAMES

### REQUIRED TOOLS

The following list identifies the main tools needed to assemble the shelter. Additional tools and supports may be needed depending on the structure, location, and application.

- Tape measure or measuring device
- Variable speed drill and impact driver (cordless with extra batteries works best)
- Wrenches or ratchet and socket set (recommended)
- Ropes long enough to reach over the frame (if optional cover was purchased)
- Hammers and gloves
- Metal file
- Duct tape (supplied by customer)
- Box cutter or utility knife
- Ladders, work platforms, and other machinery for lifting designed to work safely at the height of the frame

### UNPACK AND IDENTIFY PARTS

The following steps will ensure that you have all the necessary parts before you begin to assemble the shelter frame.

1. Unpack the contents of the shipment and place where you can easily inventory the parts. Refer to the Bill of Materials/Spec Sheets.
2. Verify that all parts listed on the Bill of Materials/Spec Sheets are present. If anything is missing or you have questions, consult the Pictorial Parts Guide and all diagrams for clarification, or contact Customer Service.

**NOTE:** At this time, you do not need to open the plastic bags containing smaller parts such as fasteners or washers (if equipped).

### SPECIAL NOTE: Baseboards for Frame

These instructions describe installing a baseboard (recommended) at ground level along each side of the frame. The baseboard runs from the front to the back of the frame.

This baseboard is *not included* with the shipment and must be supplied by the customer. Treated or recycled plastic lumber can be used for a baseboard.

The baseboard, when installed properly, helps prevent the ground posts from sinking into the ground when anchored. Depending on the building, it also provides a surface to attach struts or other building components.

Consult these instructions, or contact Customer Service for additional information regarding baseboards.



The following graphics and photos will help you identify the different parts. (Some parts are not shown.)



FA4482B  
Tek Screw



QH1073  
Post Driver



102548  
Cross Connector



102856  
End Clamp



QH1402  
Band Clamp



102675  
Ground Post

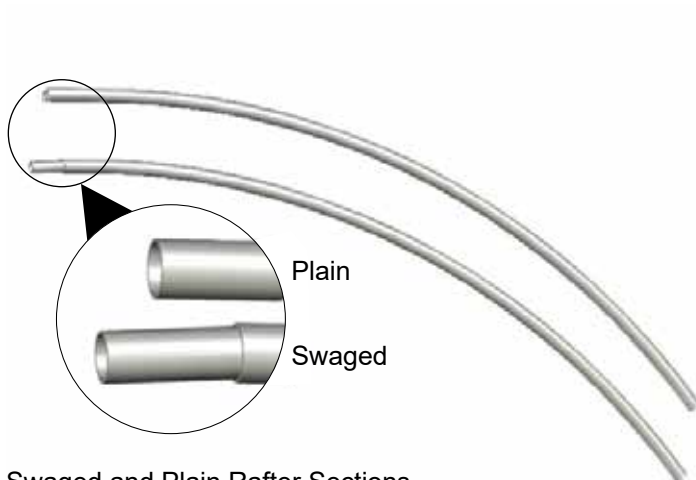

Swaged and Plain Rafter Sections



## GrowSpan™ Round Cold Frames

### OVERVIEW

This section is an overview of the process for assembling your cold frame. For details, please see section, Assembling the Cold Frame Components. See illustration below to identify main parts of the cold frame.

1. Locate the required parts for each assembly procedure.
2. Assemble the rafters and frame.
3. Anchor the frame.
4. Attach cover. (Additional purchase required.)

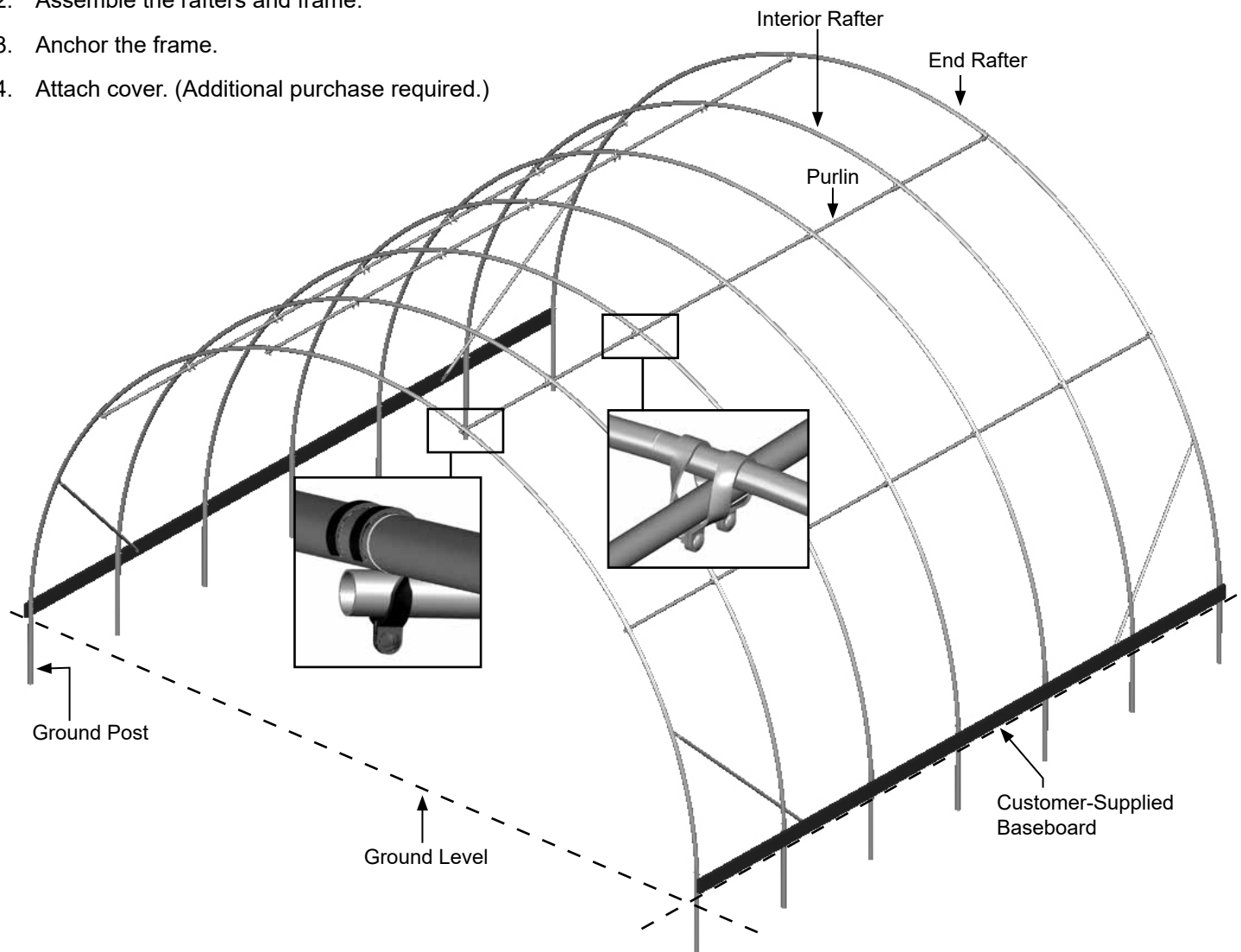

**LAY OUT THE BUILDING SITE**

After the site is prepared, lay out the building site.

Taking these steps **before** assembling the shelter saves time and ensures that the structure is positioned as desired.

*Ground posts must be driven to the proper depth. Width of the shelter is measured from the center of one ground post to the center of the remaining ground post.*

**SQUARE THE SITE**

Gather the parts:

- Ground posts
- Post driver

1. Identify a corner where a ground post will be positioned and drive the first corner ground post into the ground.

**NOTE:** Insert the ground post driver into the top of the ground post to protect the post and drive the post into the ground. *The top of the post will be one (1) foot above the finished grade when properly driven.*

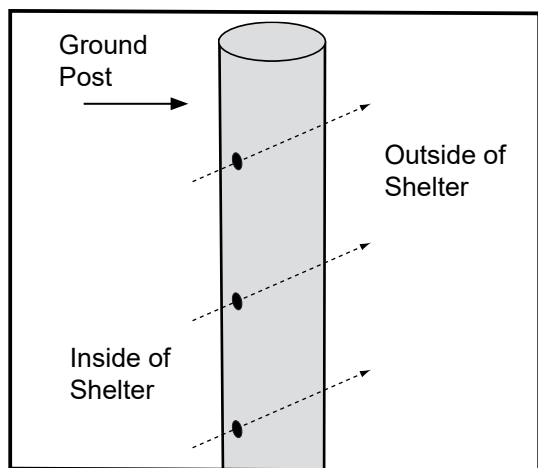

**ATTENTION:** Position the pre-drilled holes facing to the inside/outside of the shelter so they can be aligned with the bolt holes in the rafter legs.

To align the bolt holes in the ground posts with those in the rafter *after driving the ground posts*, insert a tapered rod or pry bar into a ground post bolt hole and turn the post using the rod or pry bar.

2. After the first corner ground post is in place, string a line the width of the building (26' center-to-center) and drive the second corner ground post into the ground just enough to hold it in place.
3. Use a transit or line level to drive the second corner ground post to the same depth as the first ground post.

4. String a line at least as long as the building 90° from the line between the first and second corner ground posts.

**NOTE:** A transit can be used to ensure an accurate 90° angle, or the 3-4-5 rule can be used. Refer to diagram. Using multiples of 3-4-5 such as 6-8-10 or 12-16-20 helps to maintain an accurate 90° angle.

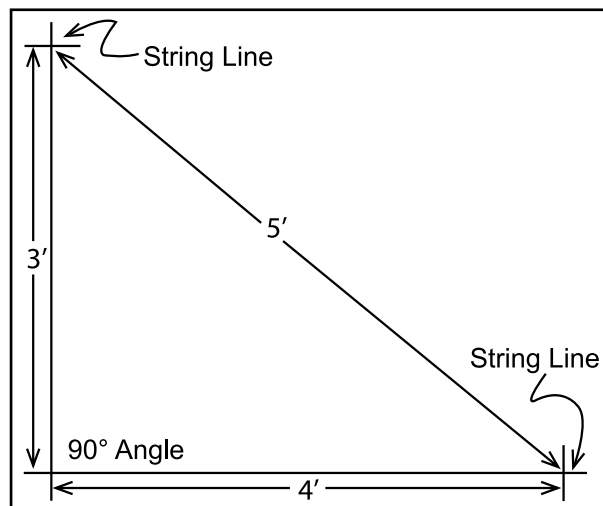

5. After squaring the position of the building, measure the length and drive the third corner ground post.
6. Repeat the same step for the last corner ground post.

**NOTE:** The distance measured diagonally between corner ground posts must be equal for the building to be square.

7. Check all dimensions (and adjust if needed) before driving the remaining posts to the required height.
8. After all four corner posts are accurately installed, tie a string line between the tops of the corner ground posts on the same side of the shelter. The string is used to identify the tops of all remaining ground posts. The string must remain tight and level.
9. Use a tape measure to mark the 48" on-center locations of the remaining ground posts.
10. Drive the remaining ground posts into the ground at the required 48" on-center width and the height identified by the string.

**NOTE:** Verify that the holes in the ground posts are in the proper position and that each post is plumb and driven to the correct depth.

11. Continue with the **Rafter Assembly** steps that follow.

## GROWSPAN™ ROUND COLD FRAMES

### ASSEMBLING THE COLD FRAME COMPONENTS

**NOTE:** Assistance is required to assemble the frame.

#### RAFTER ASSEMBLY

Gather the parts:

- Round rafter pipe swaged (#26R1601D)
- Round rafter pipe swaged (#26R1601)
- Round rafter pipe plain (#26R1602)
- End clamp (#102856)
- Band clamp (#QH1402)
- Tek screws
- Nut setter (3/8" x 2-9/16" magnetic) - supplied by customer

#### Rafter Assembly Procedure

Each rafter assembly consists of five (5) rafter pipes: two (2) swaged pipe sections (#26R1601D) (drilled for ground posts), two (2) swaged pipe sections (#26R1601) (not drilled) and one (1) plain pipe section (#26R1602).

1. Select the five (5) pipes needed to assemble a rafter and arrange these on a flat surface as shown below for assembly.

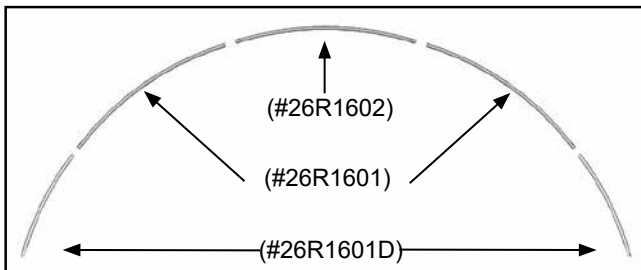

2. Slide the swaged portion of each rafter pipe into the plain end of the pipe as shown.

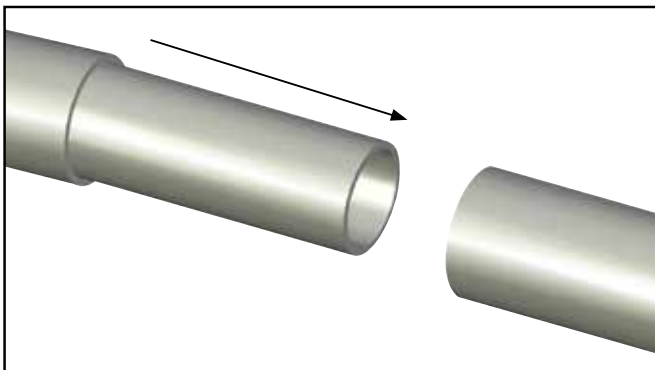

3. With the main rafter pipes seated at each joint and the rafter positioned on a flat surface, secure only the two center joints with a self-tapping Tek screws.

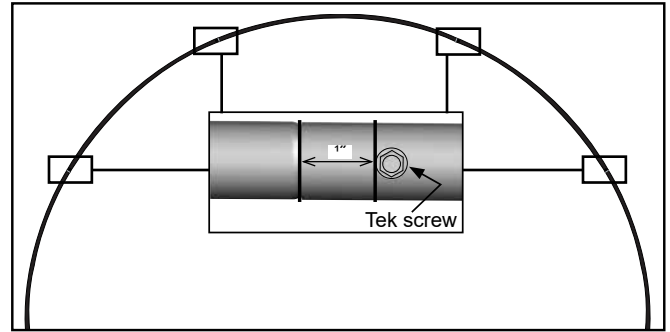

**ATTENTION:** Do not secure the drilled pipes until the rafter is attached to the ground posts. This allows holes in the drilled pipes to be aligned with those in the ground posts.

Install the screws so they will not touch the cover once it is installed (if equipped). This is typically on the backside of the rafter, which will be the surface visible from the *inside* of the shelter once the frame is assembled.

4. Assemble all the rafters as described and continue with the steps to complete two (2) end rafters.

#### END RAFTER ASSEMBLY

Complete the following steps *for the two (2) end rafters only*.

1. Take one of the assembled rafters and place it on a flat surface.
2. Slide four (4) end clamps and two (2) band clamps onto the rafter in the locations noted below.

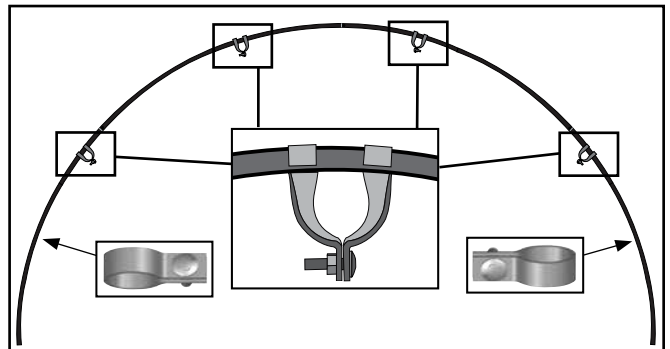

**NOTE:** Do not secure the clamps to the rafter at this time. These clamps will be repositioned during frame assembly when the purlin is added.

Use a piece of duct tape (if desired) to keep the clamps from sliding when the rafter is lifted into position. View of the end rafter and clamp as shown from the *outside* when the frame is assembled.

3. Repeat the same procedure for the final end rafter.
4. Continue with the **Frame Assembly** instructions.

**FRAME ASSEMBLY**

Gather the parts:

- All rafter assemblies
- Pipe 1.315" x 75" swaged purlin (#131S075)
- Pipe 1.315" x 73.5" plain purlin (#131P0735)
- Struts (#QH1304)
- Cross connectors (#102548)
- 5/16" x 2-1/2" machine bolts and 5/16" nuts
- Lifts, ladders, and assistants as needed

**Frame Assembly Procedure**

1. Using the proper lifts and with assistance, carefully stand the first end rafter assembly and place the leg pipes into the first set of ground posts.

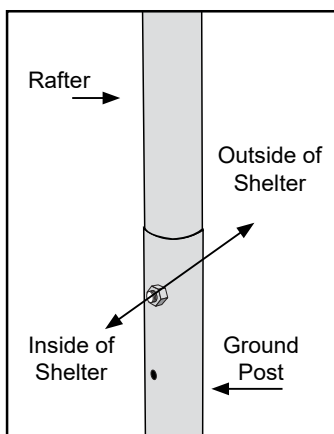

**IMPORTANT:** Brace the first rafter in position as needed to keep it from moving. Bracing is removed *after* additional rafters are installed and secured to the other rafters.

2. Align the top hole in the ground post with the hole in the rafter and insert a 5/16" x 2-1/2" machine bolt with the head to the outside of the shelter. Install the nut.
3. Place an inside rafter assembly into the second set of ground posts and secure the rafters to the ground posts as previously described.
4. Take one (1) swaged 75" purlin section and insert the plain end through one of the upper clamps on the end rafter and through the cross connector at the top of the inside (or second) rafter as shown below.

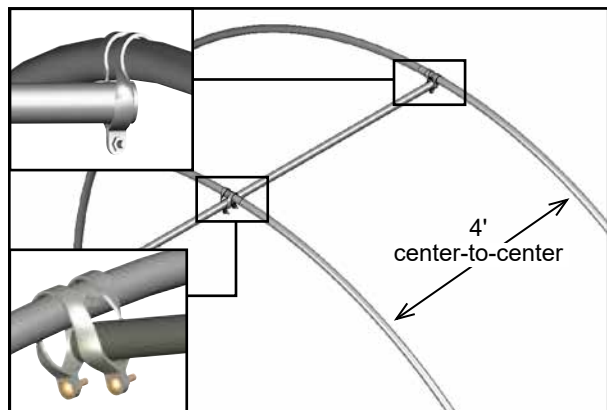

5. Verify that both rafters are plumb and properly spaced (4' on center).
6. Tighten the cross connector on the inside rafter and tighten the end clamp on the end rafter to secure the purlin pipe.

**NOTE:** The purlin assembly consists of 1.315" x 75" (#131S075) swaged pipes and one (1) 1.315" x 73.5" (#131P0735) plain pipe.

7. Move to the other clamp positions and repeat Steps 4 through 6 to install the purlin pipes in those locations.
8. Continue adding rafters and purlin pipes until the frame is assembled. Secure all purlin splices using Tek screws. See Step 10.
9. Finish the purlin using the plain, shorter pipe (#131P0735). Attach it to the final end rafter to complete the frame assembly.

**NOTE:** If the last end rafter is plumb and the purlin extends beyond the end of the rafter, cut the last section of purlin pipe to the required length.

Typically purlin pipes *do not* require cutting. *Verify that you have the correct plain pipe before you decide to cut any pipe to complete the purlin.*

**CAUTION:** To prevent damage to the optional cover, the ends of the purlin should extend no more than 1/2" past the end clamp. The bolt side of the end clamps must go toward the "inside" of the shelter (the same side as the purlin).

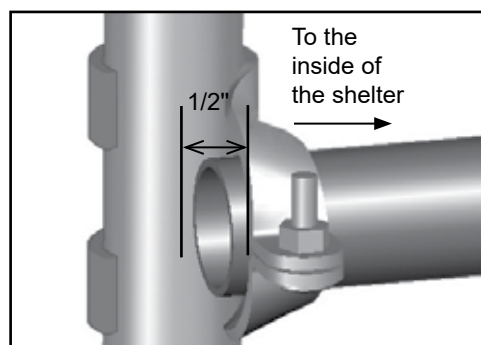

10. Once all rafters are set and the purlins are in place and secured, return to each end clamp and cross connector and install a Tek screw through each clamp and into the rafter to secure the clamps.

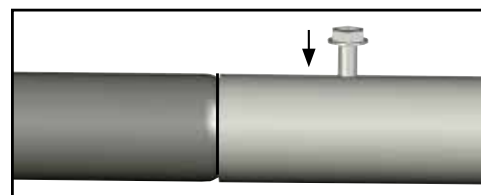

11. Return to each rafter and, using Tek screws, secure the joint between the lower rafter pipes and the upper rafter pipes and continue with the following procedure.

## GROWSPAN™ ROUND COLD FRAMES

### BASEBOARD INSTALLATION (RECOMMENDED)

Gather the parts:

- Treated or recycled plastic lumber (supplied by customer)
- 1/4" x 3-1/2" carriage bolts and nuts (may not work for baseboards with a thickness greater than 1-1/2")

**NOTE:** The following procedure describes one way to install the recommended baseboards. The size and type of the baseboard you choose may require the use of alternative steps. When properly installed, baseboards run the length of the frame.

On the outside of the frame, attach the first baseboard to the ground posts using the 1/4" x 3-1/2" carriage bolts and nuts. Continue adding baseboards to complete the first run. Splices are made between posts as shown. Use a short section of baseboard to secure separate baseboards at a splice.

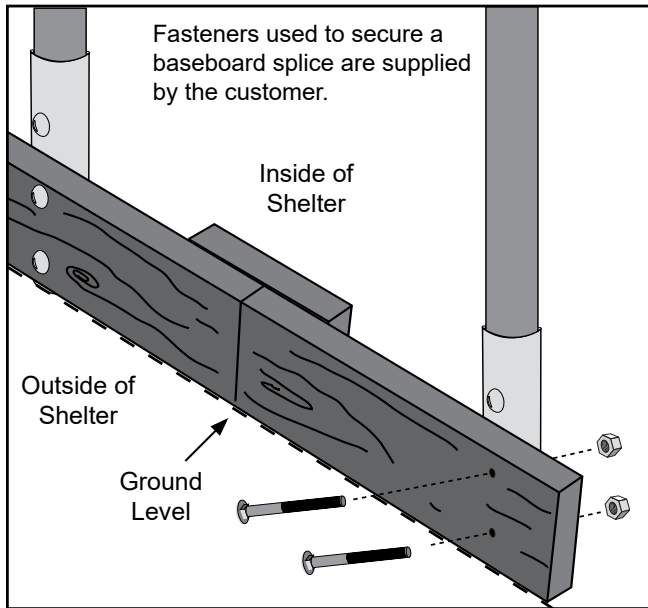

**NOTE:** The boards should be at ground level or slightly into grade to prevent the shelter from sinking and to create a seal along the bottom. After installing the baseboards, continue with these instructions.

This baseboard is *not included* with the shipment and must be supplied by the customer. Treated or recycled plastic lumber works well for a baseboard.

The baseboard, when installed properly, helps prevent the ground posts from working into the ground. Depending on the building, it also provides a surface to attach struts or other building components.

Continue by installing the side struts.

### SIDE STRUT INSTALLATION

There are four (4) side struts for the shelter. These struts are positioned between the first interior rafter and the second interior rafter on each side of the shelter.

Complete these steps to install the four (4) side struts:

Gather the parts:

- Struts
  - Wood screw (FA4368B)
1. Locate one strut and position it between one first interior rafter leg and the leg of the second interior rafter as shown below.

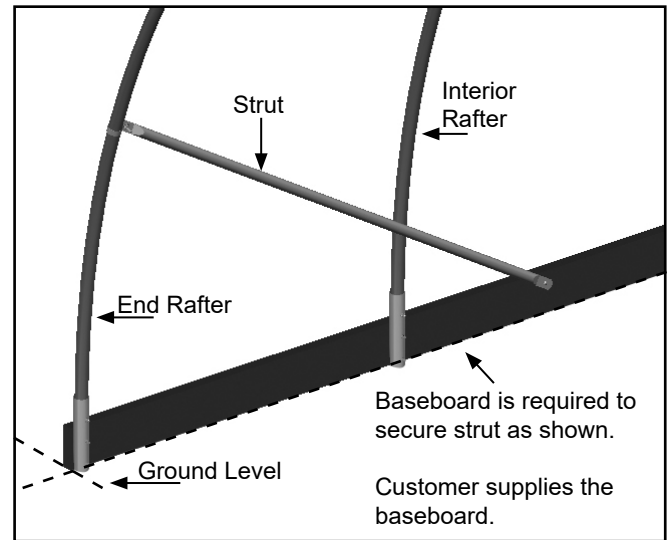

2. Attach one end of the strut to the band clamp as shown in the diagram below.

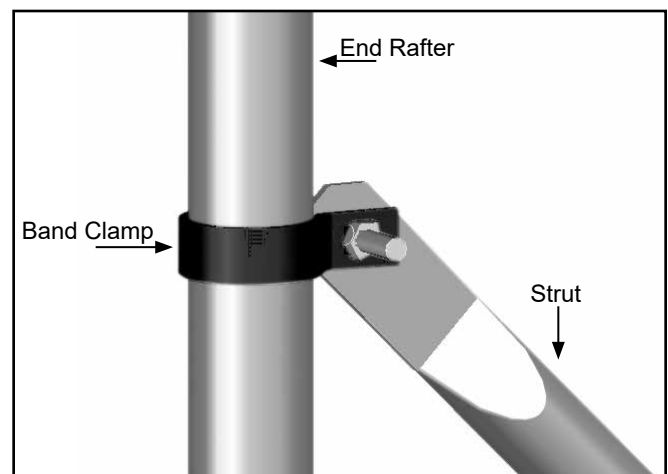

**NOTE:** Head of bolt on the band clamp must face the outside.

**SIDE STRUT INSTALLATION (CONTINUED)**

Attach the remaining end of the strut to the baseboard using a lag screw or nut and bolt (not included). See the diagram that follows for location.

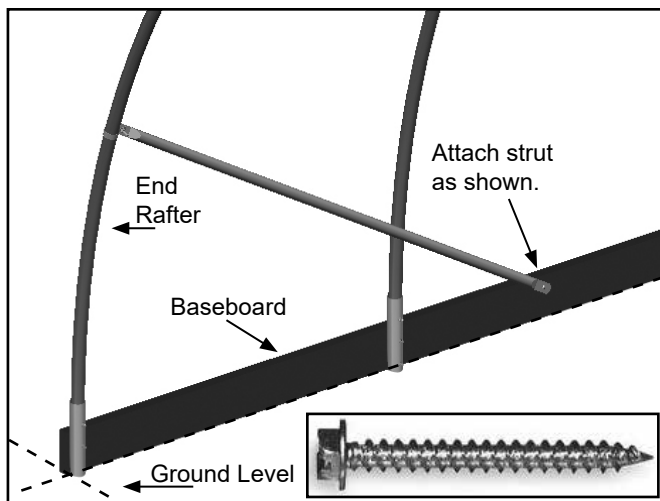

Photo shows the strut attached to the inside of the customer-supplied baseboard.

**NOTE:** A baseboard provides a place to attach each strut and helps keep the ground posts at the required depth. The customer is responsible for providing a baseboard for this frame.

If no baseboard is used, pre-drill mounting hole in ground post, reposition strut and attach using wood screw (FA4368B).

3. Repeat the above steps to attach the remaining side struts to the shelter.
4. After securing the struts, verify that all clamps are secured with a Tek screw to the rafters.
5. Continue the next procedure to anchor the assembled frame.

**ANCHOR THE ASSEMBLED FRAME**

At this point, anchor the frame. Consult the MUST READ document for anchoring information and suggestions. Please call customer service at 1-800-245-9881 for additional anchoring information.

**CAUTION:** The anchor assembly is an integral part of the cold frame construction. Improper anchoring may cause instability and failure of the structure to perform as designed. Failing to anchor the shelter properly will void the manufacturer's warranty and may cause serious injury and damage.

**OPTIONAL COVER INSTALLATION** (Cover is not included with standard cold frame. Additional purchase is required if installing a cover and/or roll-up side accessory.)

The following sections describe the installation of a film cover. The cover shown in the following diagrams may differ from the actual cover. It is shown to illustrate a basic cover installation.

Additional parts and supplies must be purchased to complete the cover installation. *These are not included with the basic cold frame components.*

Contact Customer Service if you want to purchase a cover for your cold frame and to determine which cover and additional components are best suited for the application.

**FINISH ROUGH EDGES**

Gather the parts:

- Duct tape (supplied by customer)
  - Metal file
1. Check for any sharp edges on the frame and file them smooth so they will not cut the cover.
  2. Apply two layers of heavy duct tape on all pipe connections and clamps that may contact the cover.

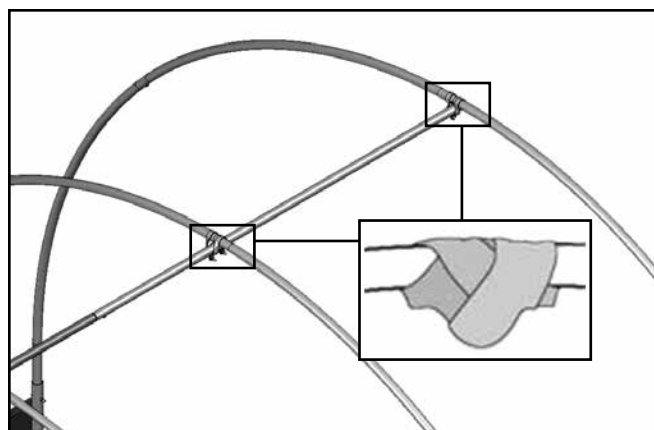

## GROWSPAN™ ROUND COLD FRAMES

### OPTIONAL MAIN COVER INSTALLATION

After the frame is assembled and the baseboards are attached to the frame, the optional cover can be installed.

The steps to install the main cover include:

1. Install poly latch U-channel on the tops of the end rafters and to the baseboard.
2. Pull cover over the shelter.
3. Attach the main cover to one peak, stretch to the other peak and secure with poly latch spring.
4. Stretch the cover along one side and attach.
5. Stretch to other side and attach.

#### Install Poly Latch U-Channel for Main Cover (No Roll-Up Sides)

**NOTE:** If you are installing a film cover and intend to have the optional roll-up sides for that film cover, skip this procedure and continue with the **OPTIONAL MAIN COVER INSTALLATION WITH ROLL-UP SIDES** procedure.

1. Using Tek screws, attach a section of the poly latch U-channel (#102179) to the top of the first end rafter. Begin at the *top of the baseboard* as shown below.

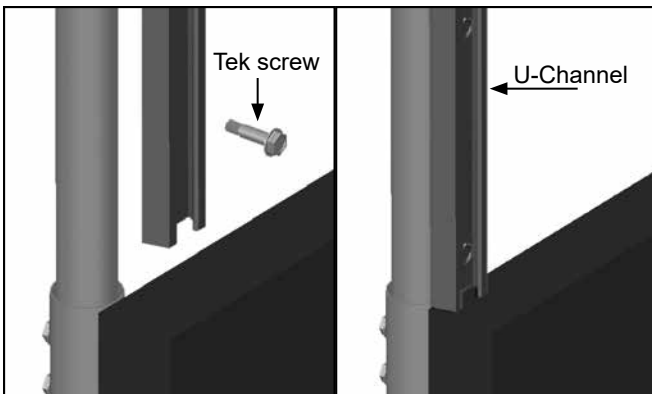

2. Continue to attach the U-channel sections working up and over the first end rafter.

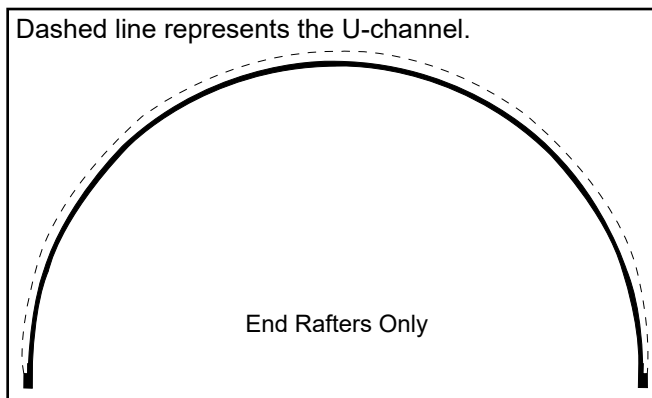

**ATTENTION:** The U-channel is attached to the top of the rafter and will bend with the curve of the rafter as it is attached. See diagram that follows.

3. Repeat these steps for the remaining end rafter.
4. After attaching the poly latch U-channel to the tops of the end rafters, use Tek screws to attach the U-channel to the baseboard as shown. (See dashed line below.)

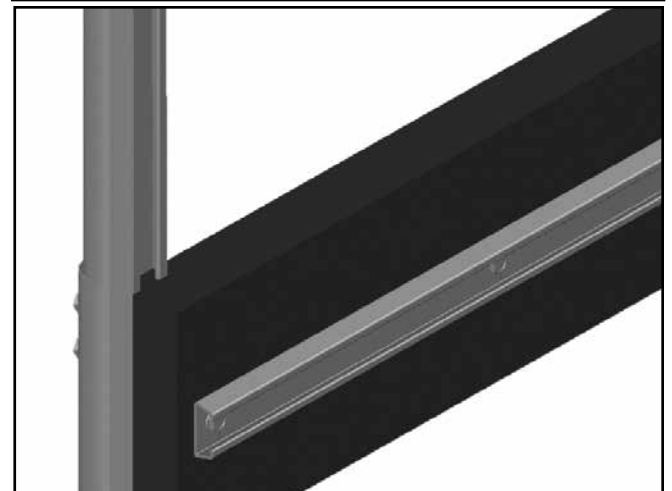
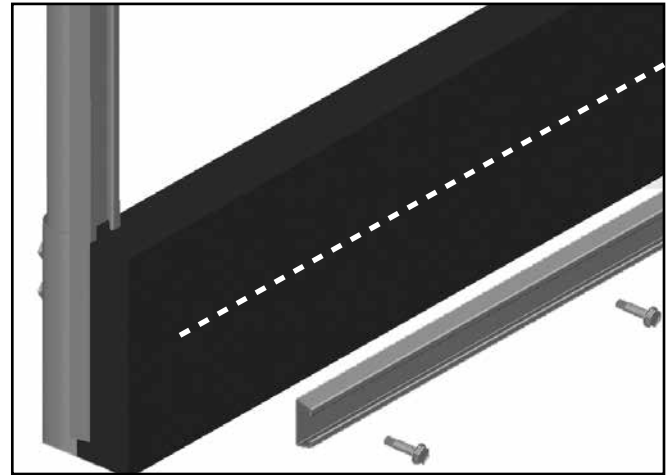

5. Continue to attach the U-channel until it has been installed on both baseboards.
6. Continue by installing the main cover.

**COVER INSTALLATION (CONTINUED)**

**Install the Cover Film**

After all of the poly latch U-channel is attached to the shelter, the cover film is unpacked and pulled into place. Assistants positioned inside the frame along the length of the film edge can help when pulling the film into place. In some instances, ropes or straps are used to pull the cover film onto the frame depending on the length of the cover and the width of the frame.

**⚠ WARNING:** To prevent damage to the cover and to prevent serious personal injury, **DO NOT** attempt to install the main cover on windy or stormy days.

Continue with the steps that follow.

1. Unpack the cover film and position it at the base along one side of the frame.
2. With assistance, pull the cover film over the frame.

**ATTENTION:** Depending on the height and width of the frame, ropes can be tied to the film edge, thrown over the frame, and pulled to lift the cover film into place. See the diagram below.

The ropes must be long enough to reach over the top of the frame to the other side. Long buildings will require additional ropes to prevent tearing the cover film when it is pulled into place.

3. With the film in place on the frame, center the cover side-to-side and end-to-end.

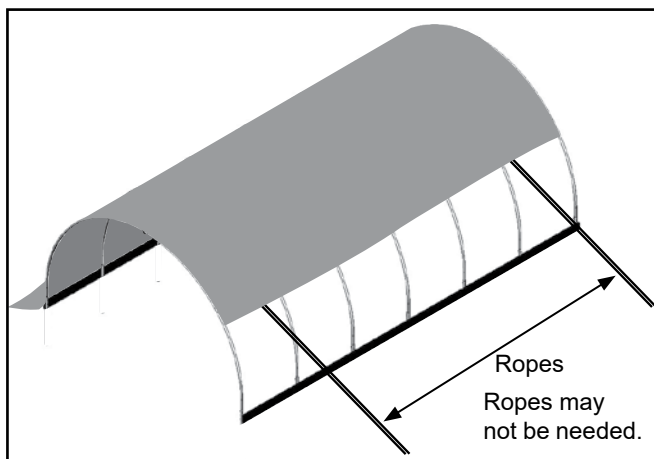

Shelter shown may differ than the actual model.

**IMPORTANT:** To prevent damage to the main cover during installation, additional personnel and lifts may be needed.

4. Once the main cover is in place and centered on the frame, begin at the peak of one end rafter and install the wire spring into the U-channel to secure the cover.

**ATTENTION:** Center the main cover front to back and side-to-side to ensure that enough cover material is present to lock into the U-channel.

If used, the rope can remain in place to temporarily secure the cover if needed. Remove the ropes as the cover is secured to the frame.



Photos show installing the spring into the U-channel on the outside of a frame. The process is the same for the U-channel attached to the top of the end rafters.

5. Continue adding the spring into the U-channel at the top of the first end rafter. Ensure that an even amount of the cover is exposed and maintained along the edge of the frame as it is attached.

**NOTE:** The cover material is cut longer/wider than is required to cover the frame. For easier anchoring, allow approximately 8" to extend past the edge of the end rafter as the cover is anchored in place.

6. Continue down both edges of the first end rafter until the entire length of the end of the main cover is secured in place.
7. Stretch the cover to the other end of the building and repeat the steps to secure the main cover in the U-channel.

**NOTE:** Pull the cover tight as the spring is inserted into the U-channel.

8. After the cover is stretched end-to-end and secured using the spring and U-channel, move to one side of the frame and repeat the steps to anchor the main cover to the first side.

Begin at one end of the U-channel and work toward the other.

## GROWSPAN™ ROUND COLD FRAMES

### COVER INSTALLATION (CONTINUED)

**NOTE:** Maintain an even length along the side. The final stretching of the cover takes place when the last side is secured.

9. After securing the first side, move to the remaining side and secure it in place.



**IMPORTANT: DO NOT REMOVE TOO MUCH OF THE EXCESS COVER MATERIAL AT EACH END.** Some excess main cover material—the material that extends beyond the end rafters—should remain in place. If the main cover needs stretched in the future, remove the spring from the U-channel, grasp the excess material, pull the cover tight, and reinstall the spring.

10. Read the **Care and Maintenance** information that follows.

### OPTIONAL MAIN COVER INSTALLATION WITH ROLL-UP SIDES

#### Attach Poly Latch U-Channel

For a roll-up side application, attaching the ribbon board to the rafters and then attaching the poly-latch U-channel to the ribbon board is recommended for the best results.

**NOTE:** Ribbon board and baseboard (recommended) shown in the diagram below *are not included* and are supplied by the customer. A treated or recycled plastic 2" x 4" works well as a ribbon board.

1. Attach the ribbon boards flush with the outside edge of the end rafters at the height best suited for the application. (The height depends on the roll-up assembly.)

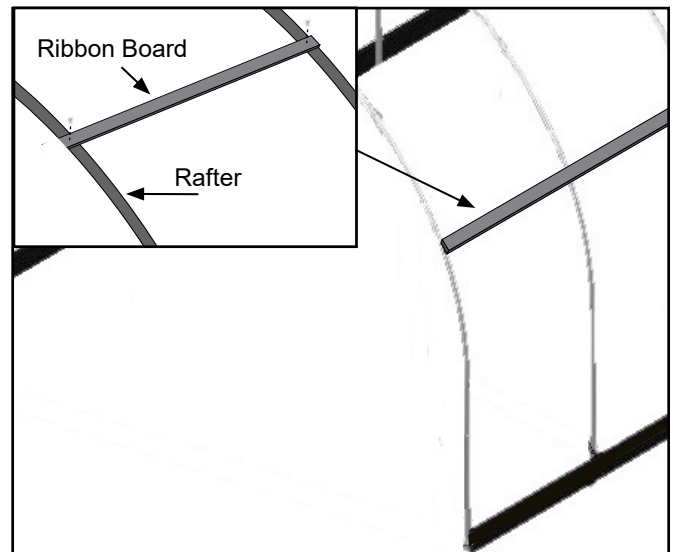

**NOTE:** Attach U-channel to baseboard or to the ground posts if no roll-up sides are desired.

2. Attach the poly latch U-channel flush with the ends of the ribbon board using Tek screws.

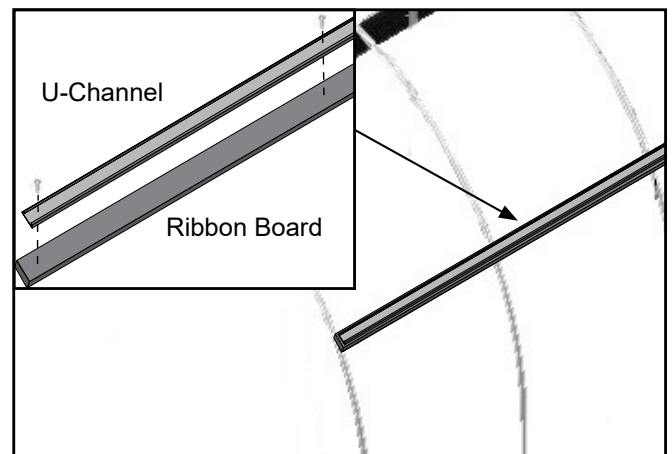

**OPTIONAL MAIN COVER INSTALLATION WITH ROLL-UP SIDES (CONTINUED)**

3. Repeat these steps for the remaining side.
4. With the U-channel secured to the sides of the frame in the desired location, attach poly latch U-channel to the top of one end rafter using Tek screws.

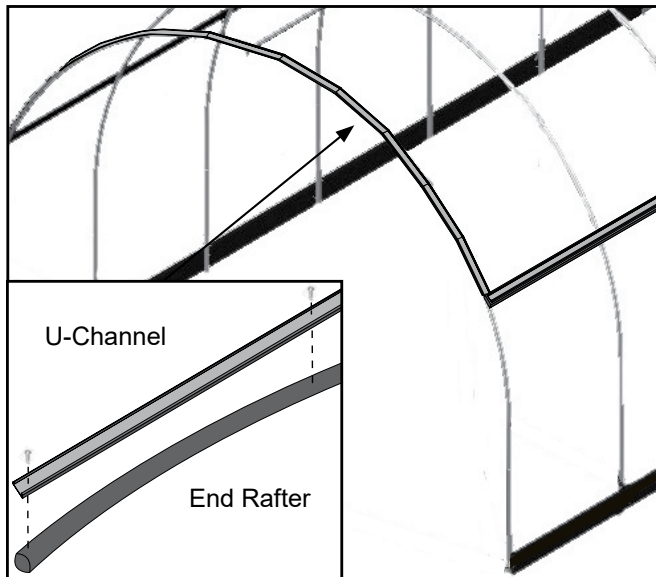

Diagram shows the ribbon board installed for a roll-up side panel. U-channel for your cold frame cover may be installed in a different location.

**NOTE:** The poly latch U-channel will bend with the curve of the rafter as it is attached.

5. Repeat the steps to attach the U-channel to the top of the remaining end rafter and continue with the main cover installation.

**Install Main Cover with Roll-up Sides**

Gather the parts:

- Main cover
- Ropes long enough to reach over the frame (provided by customer)
- U-channel spring
- Box cutter or utility knife

**Assembly Procedure**

After the poly latch U-channel is attached to the frame, unpack the main cover and pull into place. Ropes or straps are typically used to pull the main cover onto and over the frame.

**⚠ WARNING:** To prevent damage to the cover and to prevent serious personal injury, DO NOT attempt to install the main cover on windy or stormy days.

1. Unpack the main cover and position it at the base along one side of the frame.
2. Make small holes along the edge of the cover at evenly spaced intervals and tie rope to the cover. (The length of the cover determines the number of holes that are needed to attach the ropes.)

**NOTE:** The ropes must be long enough to reach over the top of the building to the other side. Long buildings will require additional ropes to prevent tearing the main cover when it is pulled into place.

3. After tying the ropes to the main cover, throw the ropes over the top of the frame and pull the cover into place. Cover must be centered side-to-side and end-to-end.

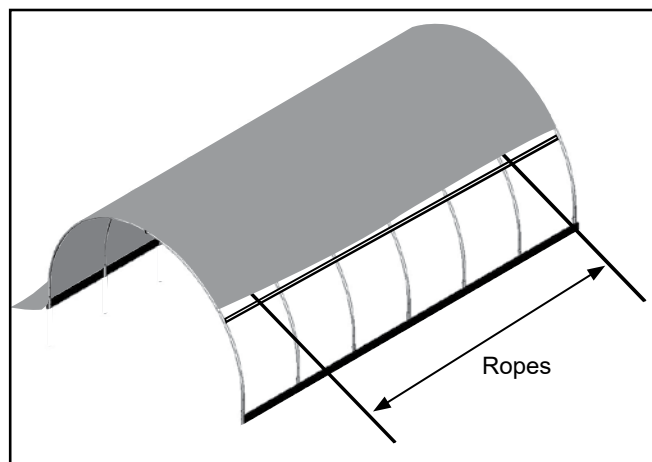

Shelter shown may differ than actual model.

**IMPORTANT:** To prevent damage to the main cover during installation, additional personnel and lifts may be needed.

4. Once the main cover is in place and centered on the frame, begin at the peak of one end rafter and install the wire spring into the U-channel to secure the cover.

**ATTENTION:** Center the main cover front to back and side-to-side to ensure that enough cover material is present to lock into the U-channel. *The excess cover along each side is rolled up when the roll-up side assemblies are installed.*

The rope can remain in place to temporarily secure the cover if needed. Remove the ropes as the cover is secured to the frame.

## GROWSPAN™ ROUND COLD FRAMES

### OPTIONAL MAIN COVER INSTALLATION W/ ROLL-UP SIDES (CONTINUED)

Photos show installing the spring into the U-channel on the outside of a frame. The process is the same for the U-channel attached to the top of the end rafters.



5. Continue adding the spring into the U-channel at the top of the first end rafter. Ensure that an even amount of the cover is exposed and maintained along the edge of the frame as it is attached.

**NOTE:** The cover material is cut longer/wider than is required to cover the frame. For easier anchoring, allow approximately 10" to extend past the edge of the end rafter as the cover is anchored in place.

6. Continue down both edges of the first end rafter until the entire length of the end of the main cover is secured in place.
7. Stretch the cover to the other end of the building and repeat the steps to secure the main cover in the U-channel.

**NOTE:** Pull the cover tight as the spring is inserted into the U-channel.

8. After the cover is stretched end-to-end and secured using the spring and U-channel, move to one side of the frame and repeat the steps to anchor the main cover to the first side.

Begin at one end of the U-channel and work toward the other. It is also possible to begin at the middle of each side and work toward each end.

**NOTE:** Maintain an even length along the side. The final stretching of the cover takes place when the last side is secured.

9. After securing the first side, move to the remaining side and secure it in place.

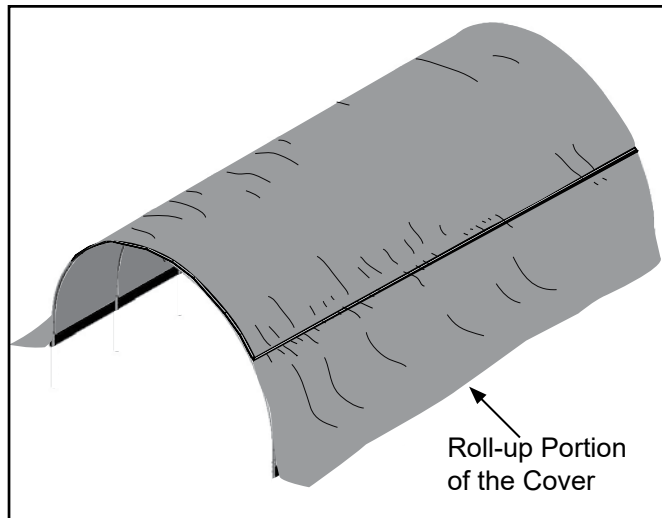

**IMPORTANT:** DO NOT REMOVE TOO MUCH OF THE EXCESS COVER MATERIAL AT EACH END. Some excess main cover material—the material that extends beyond the end rafters—should remain in place. If the main cover needs stretched in the future, remove the spring from the U-channel, grasp the excess material, pull the cover tight, and reinstall the spring.

The excess material along the sides is rolled up in the roll-up side assembly.

10. Once the main cover is installed and secured in the U-channel, follow the instructions provided with the Twist-of-the-Wrist Assembly if used.
11. Once you have completed the Twist-of-the-Wrist installation and install your Anti-Billow ropes, read the **Care and Maintenance** section that follows.

**SHELTER CARE AND MAINTENANCE**

Proper care and maintenance of the shelter is important. Check the following items periodically to properly maintain the shelter:



Space below is reserved for customer notes.

- Check the ground posts and anchoring system (if equipped) to see that all components are tight and in good repair.
- Check connections and all fasteners to verify that they remain tight.
- Verify that all connections and connectors are secure. Tighten these if necessary.
- Check the cover material (if equipped) to verify that it is in good repair.
- Do not climb or stand on the cold frame at anytime.
- Remove debris and objects that can accumulate on the cold frame. Use tools that will not damage the cover when removing debris.
- Remove snow to prevent excess accumulation. Use tools that will not damage the cover when removing snow.
- Check the contents of the shelter to verify that nothing is touching the cover (if equipped) that could cause damage.
- If the cold frame is moved, inspect all parts and connections before reassembling.
- For replacement, missing parts or additional information on optional cover, call 1-800-245-9881 for assistance.

# GROWSPAN™ ROUND COLD FRAMES



greenhouse structures

## QUICK START GUIDE

26' Wide Round Cold Frame

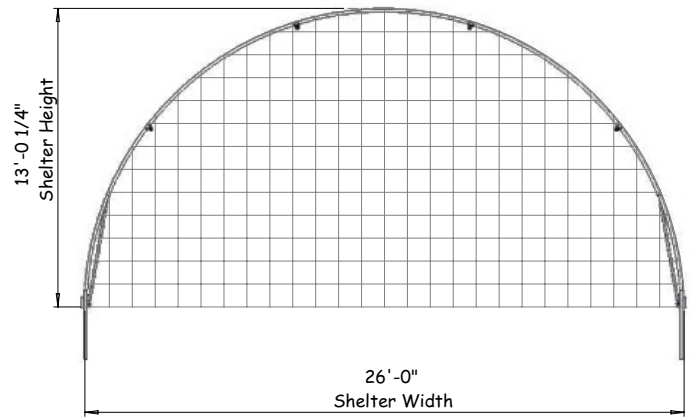

**FRONT**  
Grid Represents 12" Squares

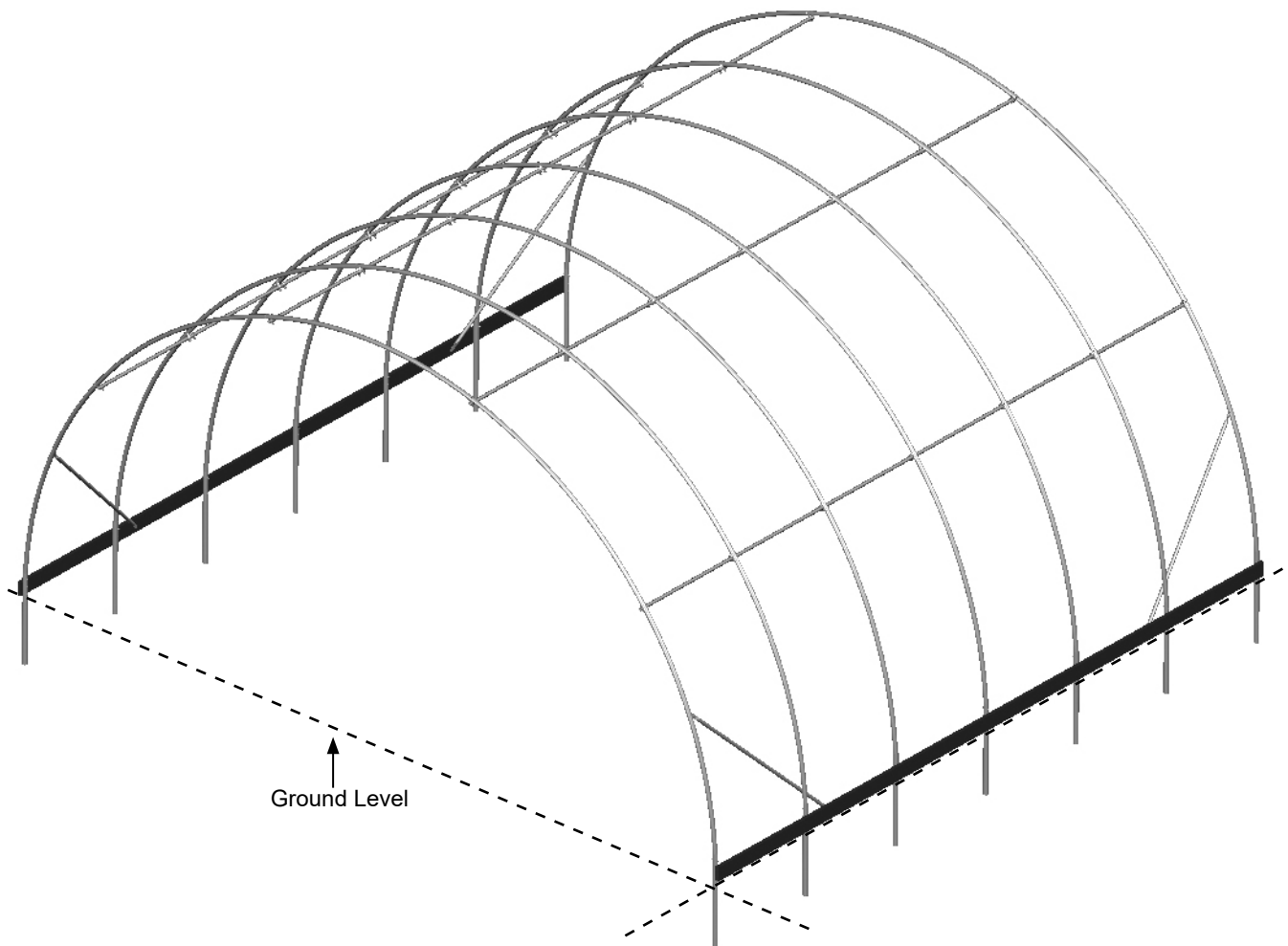

Frame shown may differ in length from actual frame.

# FRONT PROFILE

**Connection Note**

Purlin Connected to end rafters using 102856 clamp.

Purlin Connected to mid rafters using 102548 clamp.

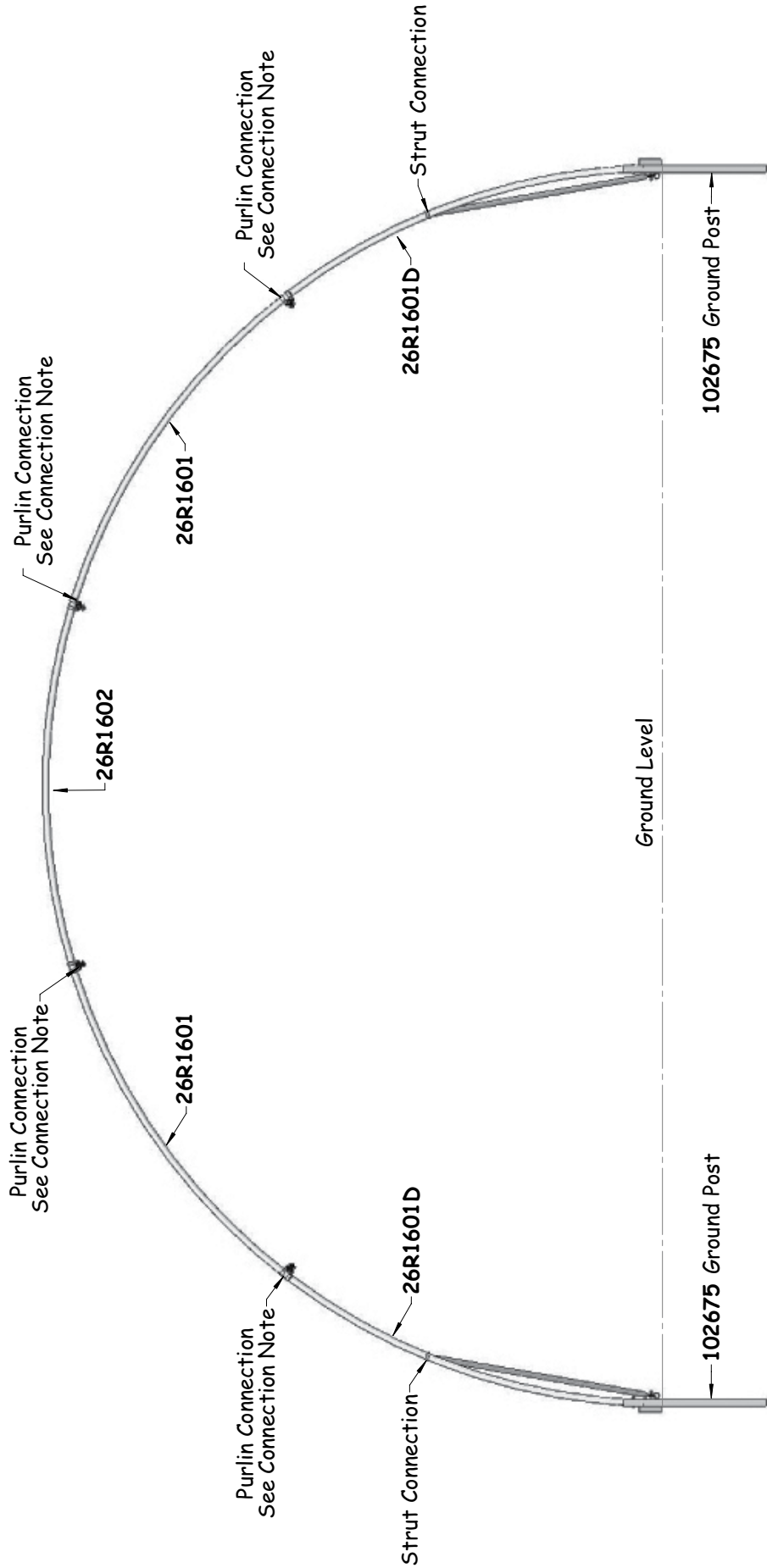

# SIDE PROFILE - 103106

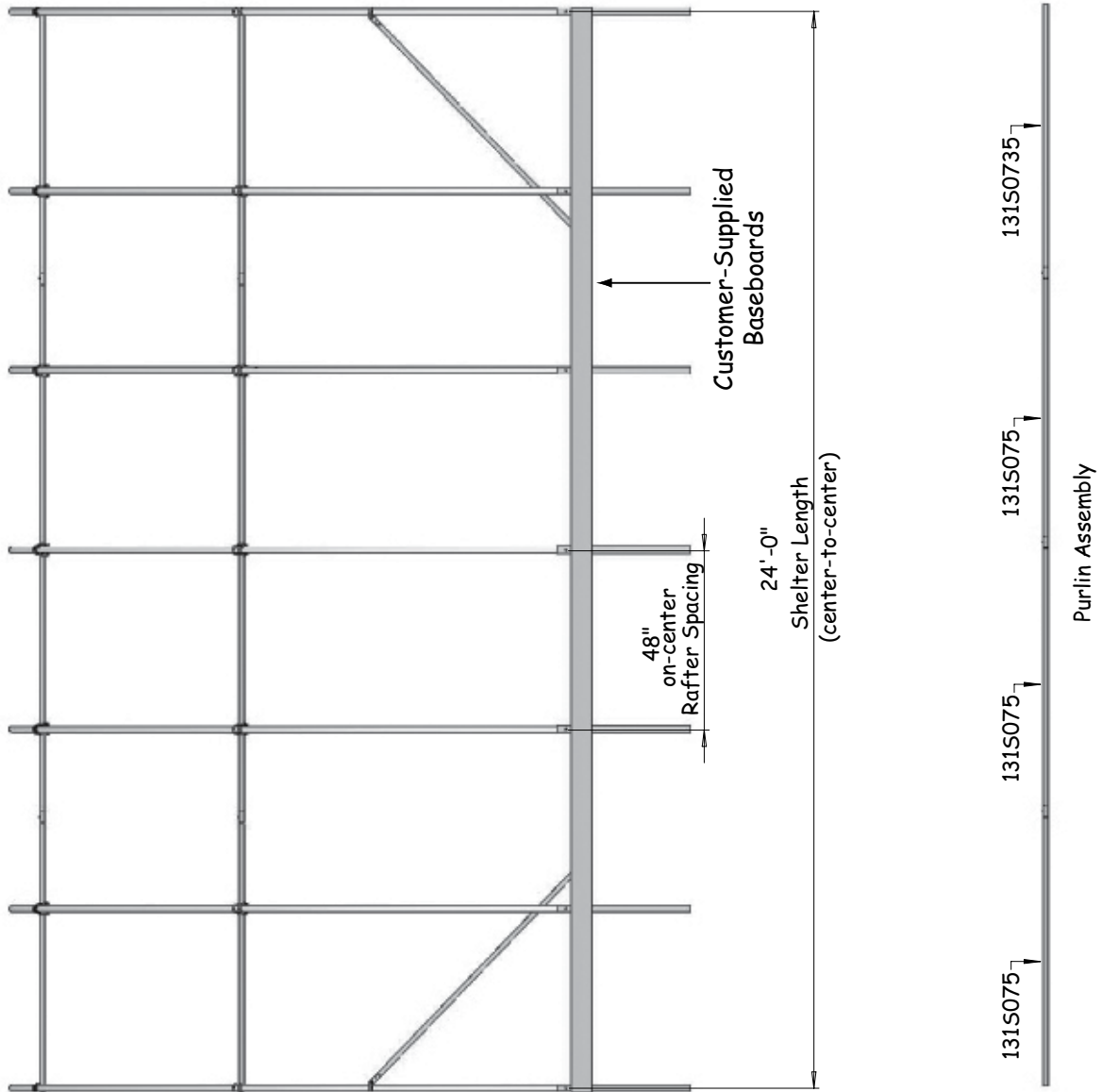

# SIDE PROFILE - 103107

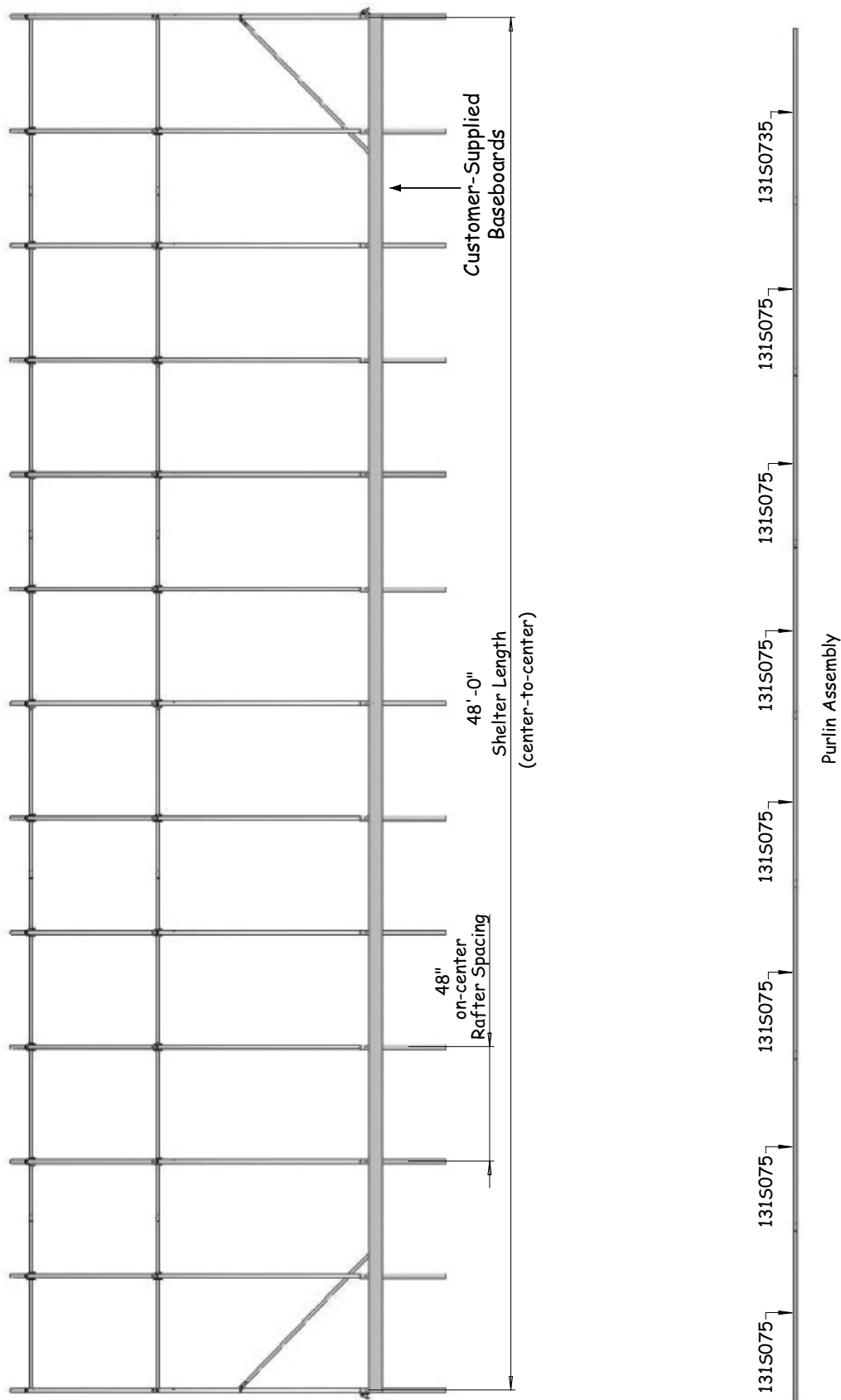

# SIDE PROFILE - 102861

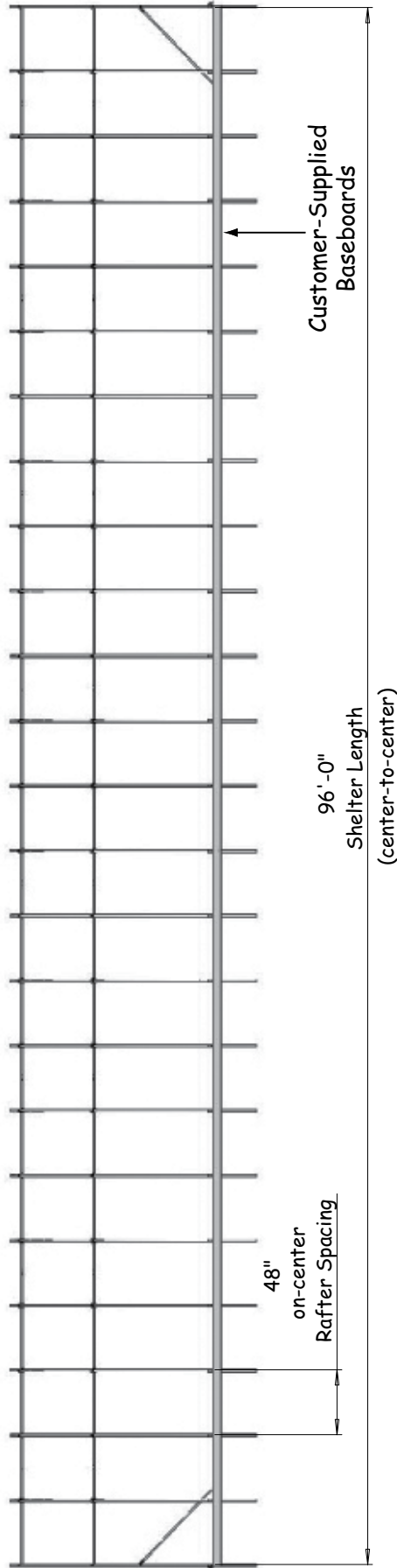

(15) 131S075 & (1) 131P0735

Purlin Assembly

# CONNECTIONS

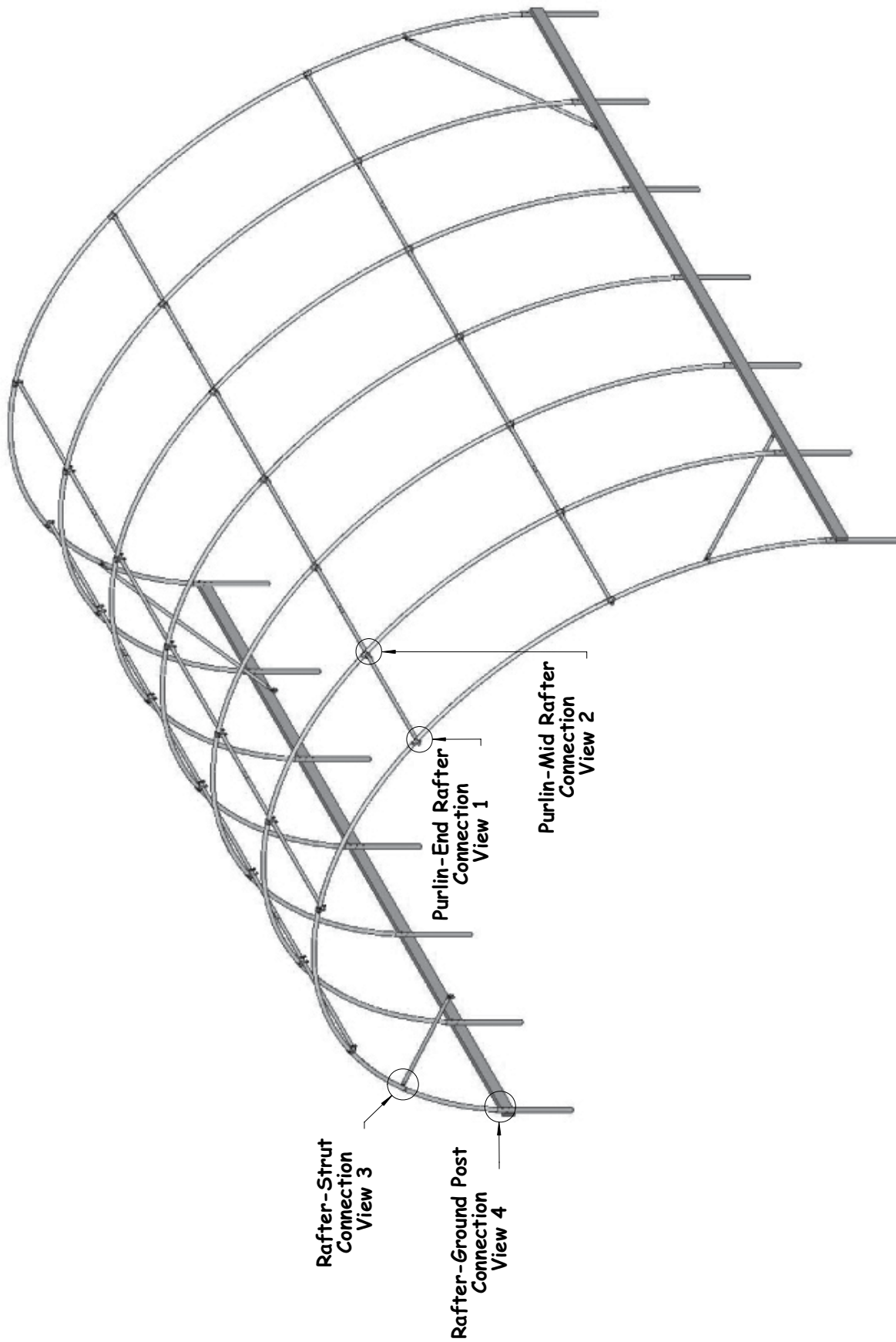

# CONNECTION - DETAILS

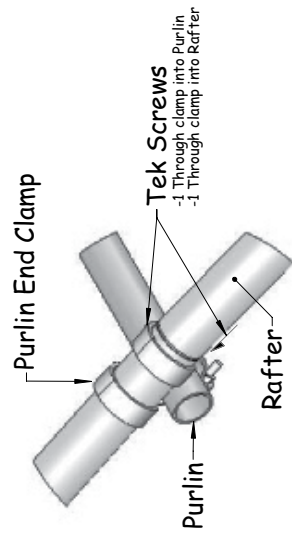

**View 1**  
**Purlin-End Rafter**  
**Connection**

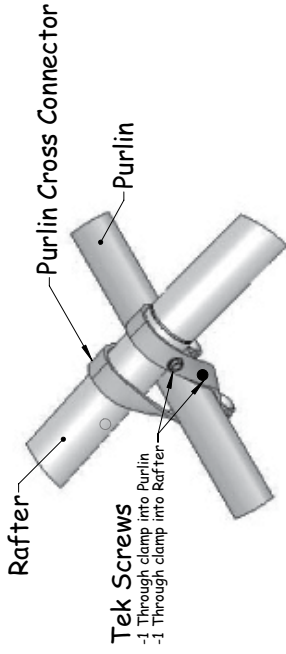

**View 2**  
**Purlin-Mid Rafter**  
**Connection**

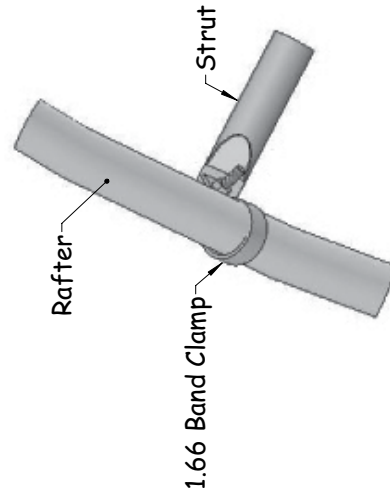

**View 3**  
**Rafter-Strut**

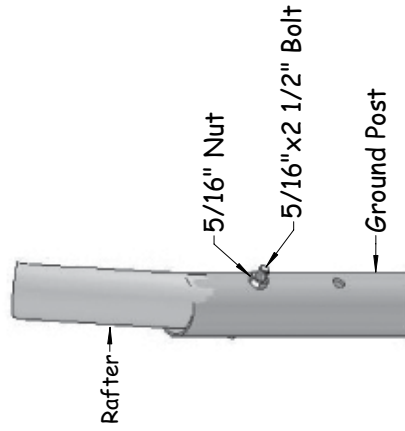

**View 4**  
**Rafter-Ground Post**



Space below is reserved for customer notes.