

J.L. Williams Company

Innovative Electric Fence Solutions

POLYTAPE FENCING MADE EASY WITH SAFE-FENCE



Safe-Fence wide polytape is an effective, efficient and economical form of livestock control that can add an attractive level of visual appearance to a property. However proper installation is required to recognize the full benefit of this product in both effectiveness and longevity.

This booklet outlines the do's and don'ts of installing wide polytape. If Safe-Fence is installed as outlined you will increase your potential satisfaction with the product, enhance it's life expectancy, efficiency and maintain the warranty.

Improper installation may result in fence failure, poor appearance and

Tel: 1•800•843•3702

Fax: 208•452•6874

Visit us on the web safefence.com

Sales@safefence.com

***I
N
S
T
A
L
L
A
T
I
O
N
M
A
N
U
A
L***

SAFE-FENCE POLYTAPE

20 YEAR WARRANTY

The Safe-Fence Electric System will be warranted 100% against ultra-violet degeneration and material or manufacturing defects for a period of five (5) years from the date of retail purchase. This warranty includes all electric fence material. The webbing is further warranted for an additional fifteen (15) years prorated at 5% per year from the date of purchase.

Proof of purchase and a sample of the failed material will be required to initiate a claim. Photographs of the installation may also be required if it is not obvious that the damage in question is due to faulty material or workmanship. Installation and maintenance must be according to manufacturer's instructions. Warranty is limited to the use of Safe-Fence Electric System hardware. Correct tightness of the tape must be maintained. Post spacing must not exceed 16 feet. Use of any fence charger other than low impedance fence charger will void warranty.

If it is determined that the failure is due to ultra-violet degeneration, faulty materials, or incompetent manufacturing procedures, the material will be replaced in accordance with the terms of this warranty and the claiming party will be reimbursed for shipping, film, and film processing expenditures. J.L. Williams Co. Inc. will not assume any liability for labor costs in replacing damaged material or claims of injury to livestock, humans, or personal property due to failures of material warranted or otherwise.

This is a material replacement warranty only and does not provide for monetary refunds.

Due to the unpredictable nature of large animals, their ownership and confinement creates certain liability risks that are the responsibility of their owners. J.L. Williams Co. Inc. makes no guarantee, expressed or implied, that the use of the Safe-Fence Electric System will prevent potential property damage, or human injury caused by an attempt to contain such animals.

Understanding Electric Fence

BASIC PRINCIPLES

In all electrical devices there are two basic components, the positive field and the negative field. The positive field is the active power or current flow of electricity consisting of voltage and amperage. The negative field in most common forms of electrical applications is the medium that connects the positive field back to itself establishing the flow of power (commonly referred to as ground or earth). The easiest way to envision this is with a light switch. When the switch is on it connects the positive wire to the negative wire allowing power to flow through the bulb and illuminate. In electric fence the positive is connected to the fence material and the negative is connected to the earth or soil. Relating electric fence power to the imagery of the light switch, when the animal, who is standing on the negative field (earth) touches the positive field (fence) it is like the light switch and the light bulb combined. Its body connects positive to negative and is also illuminated at the same time.

Supplying power to an electric fence is a much greater challenge than powering a household device. Voltage, which is the driving force of amperage, degenerates when it meets resistance. In our household devices the path that electricity must follow is clean and direct, usually over a very short distance. In electric fence applications however, electricity must flow from the fencer through the ground, into the animal and back through the ground over an undetermined distance with very poor conductive conditions. The voltage can deteriorate in these conditions to the point of becoming inadequate. It is important to understand that the animal will only feel the amount of power that returns to the fence charger through the earth regardless of the amount of power in the fence. Therefore fence chargers must produce enough voltage to accommodate deterioration and still be effective.

Studies conducted by PAMI, a Canadian testing organization, indicate that it requires approximately 700 volts to penetrate the hair, hide and hoof of short-haired livestock. When fencer power falls below 700 volts the animal will not feel a shock because the voltage is too low to break down the impedance of the animal's body. We recommend a minimum of 2000 volts of active fence power to insure effectiveness.

WHY USE ELECTRIC FENCE

Electric fence is the most effective form of livestock control for one very simple reason. It offers the same kind of natural emotional response that large animals are accustomed to in the herd environment. In other words in every herd of large animals there is a pecking order. The genetically dominant animals in many cases, regardless of size, become the accepted leader. The lesser animals of the herd respect that position. When an animal with a lesser social position challenges the dominant authority they are met with an immediate and sometimes violent response. Electric fence treats these animals in a manner that they naturally respect. A shock from a low impedance fencer is quite intense and establishes the same emotion in the animal as if it were kicked or bitten by the herd boss, but without potential injury.

With the exception of barbed wire, electric fence is the most economical fencing that can be installed. Considering that the shock of the fence is the greater deterrent and not brute strength, the need for elaborate bracing is unnecessary except with high tensile wire.

Reduced repair and maintenance of electric fence also adds to the economical value. Over long periods, electric fence requires far less consumption of time and money to maintain over most rigid products.

FENCE LOAD IS A COMBINATION OF MANY FACTORS. THE LENGTH OF THE FENCE, THE NUMBER OF STRANDS AND CONDITION OF THE WIRE OR TAPE, SPLICES IN THE WIRE, CONNECTIONS, BROKEN INSULATORS THAT CREATE SHORTS, AND FOLIAGE GROWING ON THE FENCE ALL CONTRIBUTE TO FENCE LOAD. PROPER FENCE DESIGN, CONSTRUCTION AND MAINTENANCE, ALONG WITH AN ADEQUATELY POWERED FENCE CHARGER, MAKES FOR AN EFFECTIVE, ECONOMICAL MEANS OF LIVESTOCK CONTROL.

FENCE LOAD

An electric fence is a less-than-ideal environment on which to conduct electricity. Along the course of the average fence there are many conditions which will divert or impede the flow of electricity. Collectively, these conditions are known as *fence load*.

Weeds or vegetation growing on the fence line are the most common culprit contributing to a heavy fence load. Green plants draw voltage and amperage from the fence to the earth. Other circumstances can rob the fence of voltage and amperage. Cracked or broken insulators, or insulators of poor design will allow electricity to leak to the fence post and return to earth. Sagging or broken wires can contact un-insulated wires or the ground. Wet weather will magnify all of these problems. When enough conditions exist to draw all of the electricity produced by the fence charger from the fence, the fence is said to be “shorted out.”

Rusty wire, poor splices, or wire of insufficient diameter to carry the flow of voltage and amperage also contribute to fence load. These problems do not draw voltage and amperage to earth, but they do impede the flow of electricity along the fence, contributing to the fence load.

Even the length of the fence contributes to the fence load. The longer the fence, the less ability (or greater capacitance) it has to store the energy supplied by the charger. On very long fences, capacitance can be a major contributor to fence load.

Proper construction with quality components, installing an adequately powered fence charger, and good management practices are the key to keeping fence load under control.

PROPER GROUNDING

Improper grounding is the cause for 90% of the problems experienced with electric fence. Think of the ground system as an underground antenna, the more electricity it is capable of collecting the greater the shock sensation the animal will recognize.

We recommend 3 - 6 foot ground rods spaced 10 feet apart for proper fence charger grounding. We want to ensure that you have maximum fence efficiency.

A good way to test ground rod efficiency is to place a metal rod, 12 to 18 inches long, in the ground about 3 feet from the ground rod. With a volt meter contact the short rod to the ground. If you read more than 500 volts you need to add another ground rod or replace the ones you have with longer ones.

In areas where heavy snow and ice are an issue, you may need to take additional grounding measures.

Most people don't realize that neither snow nor rainwater will conduct electricity. Frozen ground also reduces the flow of current. When animals are to be left out in electric fenced areas during frozen snowy conditions you can improve the electric fence function by running a 12 ½ gauge wire, on or just below the surface of the ground, connected to the fence posts. This wire is attached to the ground terminal of the fencer thereby creating maximum conductivity when the animal touches the fence, even in snow.

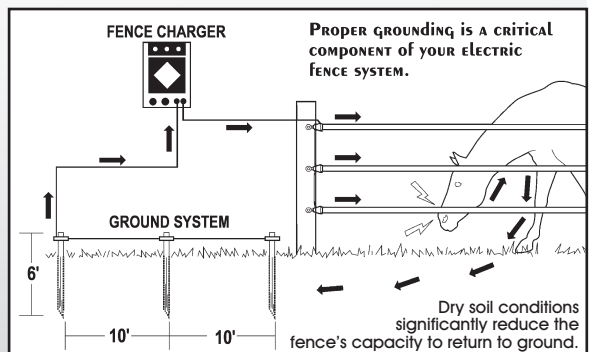



R-40 End Tensioner
Begin and end each strand with this part at gate posts or buildings. Holds webbing tight and allows easy retightening.

R-50 Corner Tensioner
Used at all corners or any up and down hill direction change greater than 10 degrees. Also used at tape gates.

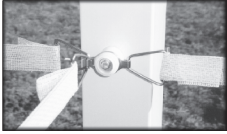
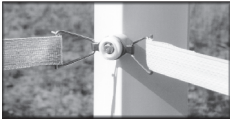

R-55 Tee Tensioner
Has three tensioners to be used at all cross fence junctions.

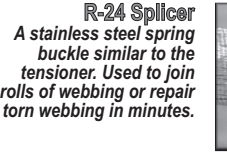

R-24 Splicer
A stainless steel spring buckle similar to the tensioner. Used to join rolls of webbing or repair torn webbing in minutes.

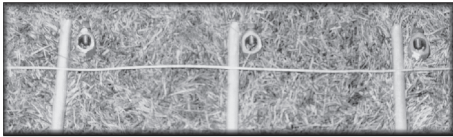
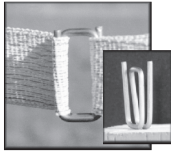

R-GR3 Ground Rod Kit
Contains 3 - 6' galvanized ground rods 3 brass clamps, 48' of 12 gauge galvanized wire.



R-16 Wood/Vinyl Insulator
A polyethylene insulator for wood or plastic line posts. The lock face holds webbing tight. Use S-16 or W-16 stainless steel screws.

TP-25 T-Post Insulator
Used on steel T-posts. When using T-posts for line posts, the corners and gate posts should be wood to accept a tensioner.

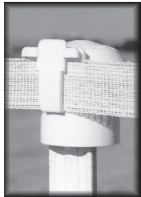
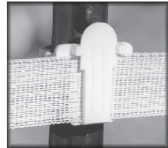

R-4 T-Post Cap
A perfect cap for the top of T-posts. Prevents horses from being impaled on the top of T-posts. Holds tape or wire.

R-79 Wire Connector
Bolts to the ring hook for a positive, easy to remove connection. Connects charger to tensioner, strand to strand.



Installation Tips

Number of Strands: Determining the right number of strands to use and the height of your fence requires some evaluation. The type of horses and the amount of property is first. If you ride as a casual pastime and have trail type, mature horses, 3 strands will be sufficient for pasture areas. **Rule of thumb:** less than 1 acre per horse use 4 strands, more than 1 acre per horse 3 strands is sufficient. If you have breeding stock with foals 4 strands is a must. Stallions, depending on their attitudes may require 5 or 6 strands, 5 to 6 feet tall. The average height of most installations is 54 inches to the top of the posts and 50 inches to the top strand. Spacing between strands would be 13 inches with 3 strands, leaving 24 inches from ground to bottom strand. On 4 strand installations, at 54 inches post height, spacing between strands would be 10 inches, leaving 20 from the ground to the bottom strand. If you are using 5 foot long Safe-Tee-Sleeves over tee-posts you may go the full 5 feet or cut of the bottoms to the height you desire. However you should never exceed 15 inch spacing between strands. Boarding facilities should always put up 4 strands at 5 feet high due to the prospect of new animals that may be unfamiliar with electric fence. It also adds aesthetic value and a very secure appearance that your customers will value. Pasture separations and in cell grazing applications 2 strands may be used were no foals are present. **Never use less than 3 strands for perimeter fencing or less than 4 strands where property parallels a highway.**

Soil: Soil condition is an issue that must be considered when installing electric fencing. Dry or sandy soil may require a fence charger with greater power than in moist areas where green foliage is abundant year around. See *Improving Your Ground System on the back cover* for more information on reliable electric fence operation in arid conditions.

Expansion: When choosing the fence charger it is recommended to not only consider the area being fenced, but to look ahead at fence to be added later. That way the right charger may be purchased the first time around.

Gates: Location of gates, type, and amount of traffic going through the area is an important consideration. Installing metal gates in high traffic areas and in corners makes handling animals easier. Electric gates are great for pasture separations or implement traffic.

R-9 Contact Clamp
Used to connect the fence charger to the webbing anywhere in fence line when a tensioner is inaccessible. Use R-28 wire.



R-12 Gate Handle - R-22 Gate Kit
The best electric gate handle made. Practically unbreakable. Includes a tensioner connector to attach wide polytape. Replaceable spring. Gate kit includes handle, 2 tensioners, and 20' of 1½" webbing.

Step 1: Location of the Fence Charger

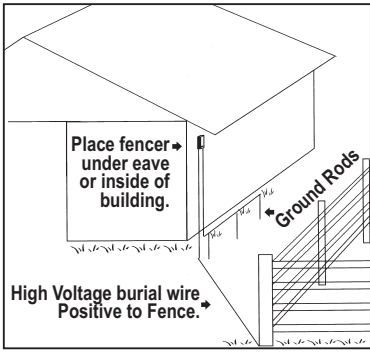

Building Installation

Locate the fence charger close to or at the fence where 110 volt power is accessible. Placing the charger under cover is recommended as under the eave or inside

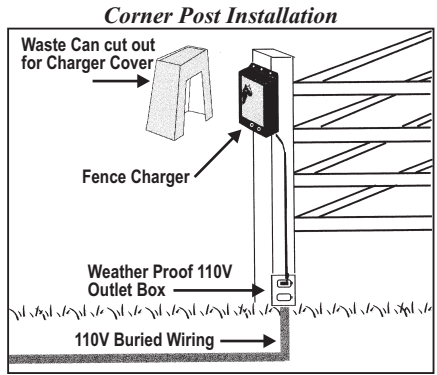

Be safe! Have all electrical wiring installed according to code by a licensed electrician.

of a building. If your power source is greater than 50 feet from the fence it is advisable to run underground 110 volt wire from the source to the fence and stub up a weather proof plug-in rather than run a long distance of high voltage burial wire. A certified electrician should be used for the installation of 110 volt wiring. When fences are located on a corner or gate post, a small, rectangular, plastic waste can is an easy way to protect the fencer from direct rain. Cut a section out of one side of the waste can to clear the mounting screws and slide it upside down over the fencer. Solar fence chargers do not require cover and should be placed in direct sun facing south.

Step 2: Ground Rod Installation

Installing a minimum of 3 - 6 foot long ground rods, 10 feet apart will insure maximum efficiency in the operation of your electric fence system. Inadequate grounding is the most common failure in electric fence operation. Consider that the grounding system of an electric fence is similar to the antennae on a television set, the larger the antennae, the greater the reception. Ground rods serve to collect the voltage as it passes from the fence, into the animal, through the earth and returns to the fence charger completing the circuit. The animal will only feel the amount of power that returns back to the fence charger, therefore it is critical that the ground field, like the antennae, is large enough to insure the collection of all available power.

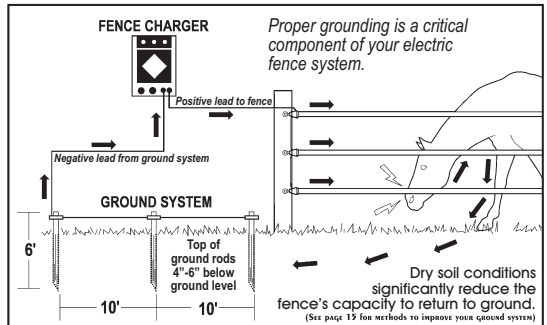

Typical Ground Rod Installation

Within 20 feet of the location of the fencer dig a 4 to 6 inch deep trench 20 feet long. This should be in an area that is out of the way of animal or vehicle traffic. Drive a ground rod into the ground at each end of the trench and one in the middle. With the brass acorn ground clamps, attach the galvanized wire to the rods laying it in the bottom of the trench.

Attach the end of the wire to the negative or ground post of the fence charger. Attach high voltage shielded wire to the positive post of the fence charger and then to the fence. Do not use unshielded wire to make connections from the fencer positive post to the fence. If there is any danger that horses may walk or run in the area of the ground rods we suggest that a coffee can be buried over the top of the ground rod ends to reduce the possibility of injury.

CAUTION: Do Not install ground rods within 50 ft. of a utility ground rod, buried telephone line, or buried water line. Shock Hazard may result.

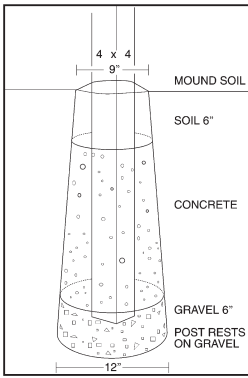

For best results dig a three-foot deep hole that is 9" wide at top and 12" wide at bottom. Put in 3 inches of gravel and center post in hole. Use level to straighten and add three more inches of gravel. Add concrete to within six inches of surface. Fill hole with soil and mound extra soil around bottom of post to keep water away from post. Allow concrete to set for 24 hours before attaching Tensioners.

Step 3: Install End, Corner & Gate Posts First

Mark, dig, and set in all of your support posts. These will be used on all gate, ends, corners, changes in elevation (low and high spots), and in spans exceeding 660 ft. to hold tension. We recommend 4"x4" square or 5"+ round or larger pressure treated post. These should be set a minimum of 3 ft. in the ground with concrete.

For a very attractive fence, use nominal 4"x4" pressure treated posts covered by Wood Post Vinyl Sleeves.

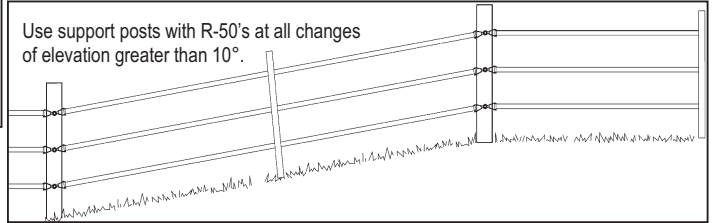

Step 4: Install Line Posts

Line posts can be wood, steel "T" posts, pipe, plastic or our attractive Safe-Tee Sleeves that fit over T-posts. Stretch string between Tensioner Posts approximately 12" high to install posts in a straight line. Recommended spacing is eight feet to 16 feet apart (in heavy snow or wind regions space no more than 8' apart). Install line posts perpendicular to the average ground level figuring slight ups and downs to keep polytape from binding or curling.

When using wood posts or tee-posts, without sleeves, it is important that the top of the posts are all level. The easy way to accomplish this is to run a second string line from the top of the corner

or gate posts. It may be difficult to get the string tight enough to be level however if the first post you set is in the middle of the fence it is easier to judge level from the middle to the end. When using Safe-Tee-Sleeves over tee-post the tops of the tee-post need not be level, as you will level the top of the sleeve instead. Just make sure to drive the tee-post deep enough that top is several inches below the top of the sleeve and the spade is a minimum of six inches below the ground level. Leveling the sleeves can be done by cutting off the bottom at each post or adding or removing soil below the post.

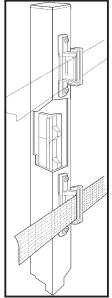

Power Across Gates

To run power across a gate opening, attach insulated cable using an R-79 wire connector to the top Tensioner, then run the cable down the post underneath the gate (if less than 1ft. deep it should be in plastic pipe) back up the other side and connect to the top Tensioner using a wire connector. Continue down that side connecting the cable to the lower strands from top to bottom allowing lower connectors to be disconnected if needed.

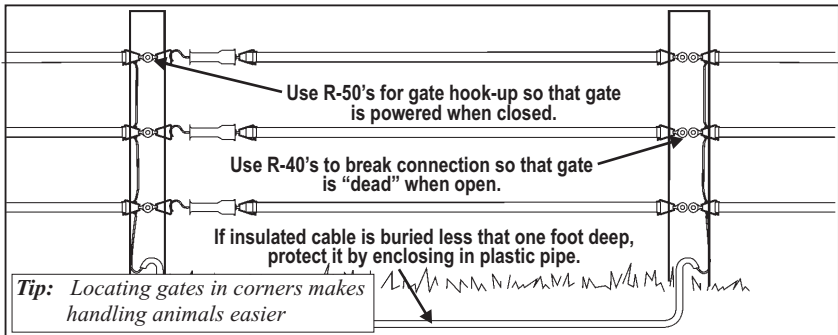

Improving Poor Ground System Conditions

Dry or barren ground is a poor conductor of electricity. Voltage returning to the fence charger will decline substantially in these conditions. In arid regions or sandy soil areas it may be necessary to install grounding around the fence to achieve maximum fence efficiency. You may ground one of the strands of fence, or the best solution is to run bare galvanized wire just below the surface of the ground, attached to each post, for optimum functionality.

Grounding a strand of fence

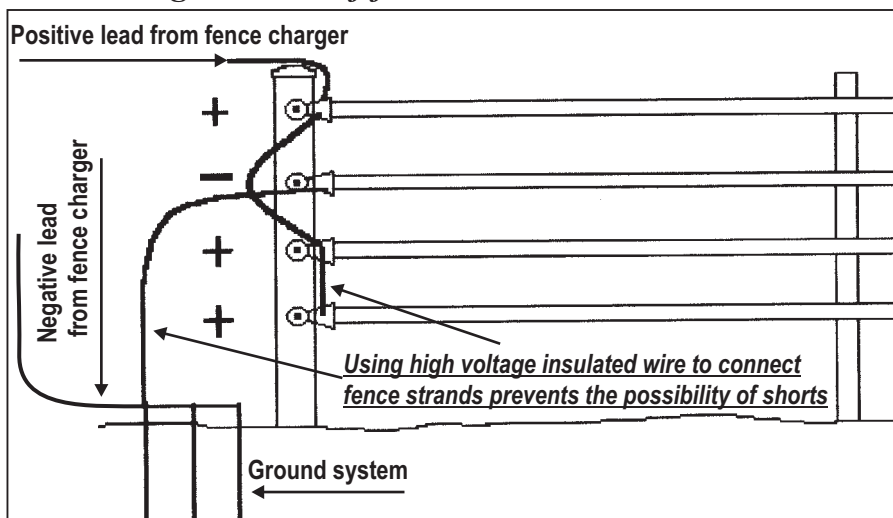

Grounding a strand of fence provides direct connection to the fence charger when the animal contacts both the negative and positive strands of fence at the same time. Because this is a direct connection, the earth's ability to return voltage to the ground system is by-passed, avoiding the limited ability of dry, arid soil to return voltage to the fence charger.

Installing a Ground Wire

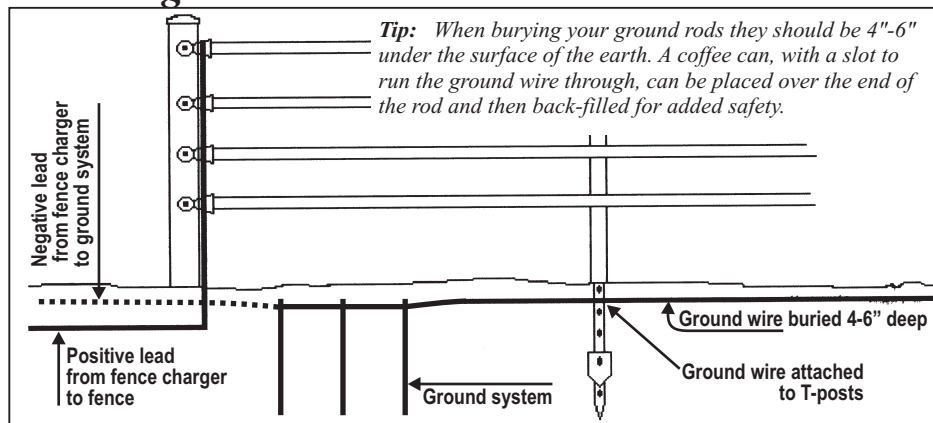

A ground wire buried along the length of the fence line and attached to the T-posts extends the reach of the ground system. Voltage has to travel only a short distance to return to ground.

The ground wire is best buried 4-6" below ground level. It may also lay on the ground stretched tight, but will present the risk of a horse pawing and hooking the wire on a shoe or in the pastern joint—exposing the horse to potential injury.