

Evaporative Cooling System — End Feed

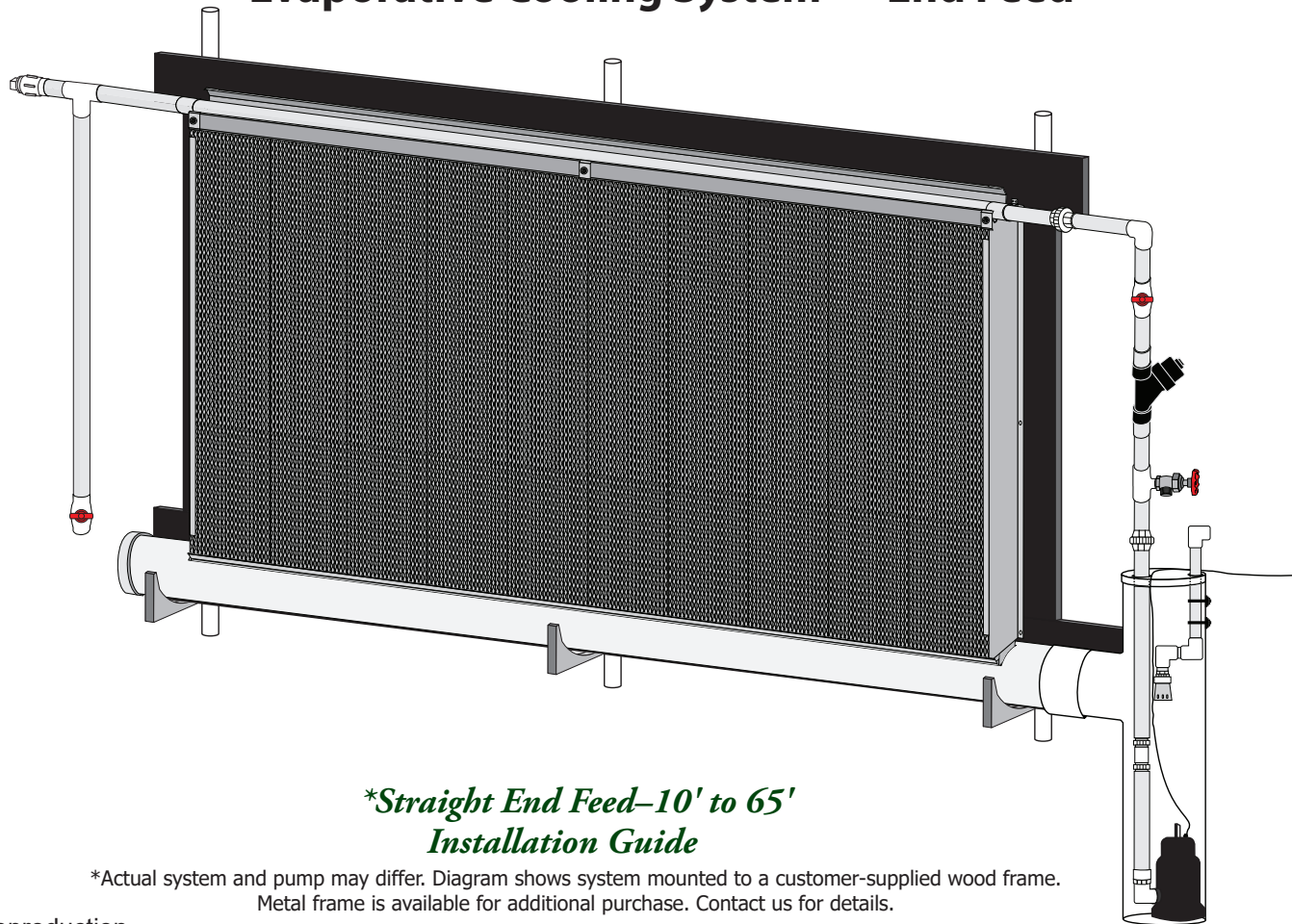

**Straight End Feed—10' to 65' Installation Guide*

*Actual system and pump may differ. Diagram shows system mounted to a customer-supplied wood frame.
Metal frame is available for additional purchase. Contact us for details.

©2023 FarmTek®
All Rights Reserved. Reproduction
is prohibited without permission.



WARNING: Cancer and Reproductive Toxicity - P65Warnings.ca.gov

IMPORTANT: Before You Begin

GREENHOUSE WITH BLACKOUT SYSTEM

If your greenhouse includes a blackout system, consult instructions and technical drawings included with the building and blackout system for critical dimensions.

ATTENTION: DO NOT INSTALL EVAPORATIVE COOLING SYSTEM FRAME (CUSTOMER-SUPPLIED OR PURCHASED) OR ANY COMPONENT OF THE EVAPORATIVE SYSTEM WITHOUT FIRST CONFIRMING REQUIRED CLEARANCES. DOING SO MAY REQUIRE DISASSEMBLY OF SOME COMPONENTS OR THE PURCHASE OF REPLACEMENT COMPONENTS OR BOTH.

EVAPORATIVE COOLING SYSTEM FRAME — CUSTOMER-SUPPLIED WOOD FRAME

Diagrams throughout this manual show the evaporative cooling system mounted to a customer-supplied wood frame. See page 8 for required clearances and lumber for customer-supplied frame. *If you purchased a metal frame kit from us for your evaporative cooling, read the information that follows.*

EVAPORATIVE COOLING SYSTEM FRAME — METAL FRAME KIT (PURCHASED) FOR S1000 & S2000 GREENHOUSE

If you purchased a metal frame kit for your evaporative cooling system, locate the kit in the shipment and consult instructions included with that kit before you begin. In addition, consult technical drawings and instructions *included with your S1000 or S2000 greenhouse and blackout system* for installation details and required clearances for the blackout system. Consult the instructions for the evaporative cooling system frame and evaporative cooling system for details regarding the installation of those frame and system components.

IMPORTANT: A customer-supplied wood frame for the evaporative cooling system *is not needed* if the evaporative cooling system metal frame kit was purchased.



IMPORTANT: IF A GUILLOTINE OR AWNING VENT WAS PURCHASED TO INSTALL IN THE END WALL OR SIDEWALL, CONSULT THE INSTRUCTIONS INCLUDED WITH THAT KIT FOR REQUIRED VENT DIMENSIONS.



ELECTRICAL WARNING

CONSULT THE SERVICES OF A QUALIFIED ELECTRICAL TECHNICIAN WHEN INSTALLING THE WATER PUMP OR ANY ELECTRICALLY POWERED ACCESSORIES.

Getting Started

READ THIS DOCUMENT BEFORE YOU BEGIN

Thank you for purchasing this evaporative cooling system. When properly assembled and maintained, this product will provide years of reliable service. This guide includes important information needed to safely assemble and maintain the system. Please read these instructions **before** you begin.

REQUIRED TOOLS

The following list identifies the main tools needed to assemble the system. *Additional tools and supports may be needed.*

- Tape Measure and Marker
- Chalk Line
- Duct tape
- Magnetic nut setter (5/16" x 2-9/16")
- PVC Primer, PVC Cement, and Pipe Thread Tape (included)
- Variable Speed Drill (cordless with extra batteries works best) and Drill Bit Set.
- Driver to install 1/4" Lag Screws
- Hammer and Gloves
- PVC Pipe Cutting Tool
- Circular Saw (with blade to cut pipes)
- Jig Saw (with blade to cut pipes)
- Hand Level 4' (or longer) & Line Level
- Wrench Set or Adjustable Wrenches
- Socket Set with Ratchet
- Adjustable Pliers
- Flat Screwdriver (long)
- Ladder or work platform to work at the height of the cooling system frame opening.

ASSEMBLY PROCEDURE

Following the instructions as presented will help ensure the proper assembly of the evaporative cooling system.

The steps outlining the assembly process are as follows:

1. Verify that all parts are included in the shipment. Notify customer service for questions or concerns.
2. Read these instructions and all additional documentation included with the shipment **before** you begin.
3. Gather the tools and assistants.
4. For best results, assemble the components in the order they are presented in these instructions.

UNPACK AND IDENTIFY PARTS

The following steps will ensure that you have all the necessary parts **before** you begin assembly.

1. Unpack contents of shipment and place where you can easily inventory the parts. Refer to the Bill of Materials/Spec Sheets.
2. Verify that all parts listed on the Bill of Materials/Spec Sheets are present. If anything is missing or you have questions, consult the Pictorial Parts Guide and all diagrams for clarification, or contact Customer Service.

CUSTOMER-SUPPLIED MATERIALS

ATTENTION: If you purchased the metal frame kit for your cooling system, framing materials and flashing are included with that kit. Continue with the next page.

Customer must supply fasteners and required **treated-wood frame** to mount evaporative cooling system. Quantity of wood depends on cooling system dimensions. Consult diagrams and tables in this guide for required frame and lumber sizes.

For evaporative systems mounted outside the building, modifications to roof may be required. See diagrams and tables in this guide for details.

FLASHING (required)

Customer-supplied flashing is required to close and finish area between end wall cladding and evaporative cooling system frame. Typically, wood or metal works best to finish these areas. **See diagram on Page 5.**

Consult the services of a qualified contractor if needed to finish these areas.

SAFETY PRECAUTIONS

- Wear eye and ear protection.
- Wear gloves when handling metal.
- Use a portable GFCI (Ground Fault Circuit Interrupter) when working with electric power tools and cords.

General Information

To achieve the best results from your evaporative cooling system, read and follow the instructions on this page and throughout this guide.

Cooling Pads: Break-In Period

New cooling pads function best after performing an initial break-in procedure. Complete these steps before normal operation begins:

1. Verify that pads have been installed according to the information provided with those pads.
2. Turn on water pump for the evaporative cooling system and adjust water flow using upper ball valve.
3. Pump water through the system and over the pads for 24 to 36 hours depending on water hardness in the area.
4. After completing Step 3, turn water off and inspect the pads. Pads should be fully saturated with no dry areas. If dry areas are present, inspect the supply header tube for obstructions and consult the supply header maintenance information near the back of this guide. Check the spray hole angle and make the necessary adjustments.

Cooling Pad Inspection, Cleaning, and Care

Daily inspection of the cooling pads during normal operation will help to identify any areas that need attention. Consult the following information to identify issues common to most evaporative cooling systems.

- Controlling Scale Deposits

Water evaporation can lead to the deposit of solids on the cooling pads. Water quality, environmental conditions, and system operation can all contribute to the buildup of solids.

Minimize or eliminate On/Off cycling of the system. Set evaporative cooling system to run continuously to minimize scale buildup on pads. Control water flow using the upper ball valve above water screen. Allowing the pads to dry out due to repeated cycling of the system increases the deposits of solids on the pads; keep the pads wet to reduce these deposits.

NOTE: Anytime air flows through wet pads, water should also be running to keep pads wet and to increase flushing of solids from the pads.

- Maintain Proper Water Level

Do not allow the bottoms of the cooling pads to sit in water at any time. Submerged pad sections become waterlogged and will deteriorate, which decreases pad life. Adjust the water level as needed to prevent this condition.

- Algae Growth and Treatment

Some environments and conditions can cause algae growth on the cooling pads. In those instances, it may be necessary to treat the water to reduce or eliminate algae. Contact water conditioning experts in your area for details and possible solutions.

- Diluting or Changing the Recycled Water

In instances where solids become concentrated in the recycled water, deposits on the cooling pads can increase. If this happens, dilute or change the water in the reservoir. To dilute, drain water from and add it to the system. Complete these steps:

1. Turn off the water pump and main water supply to the system and attach a garden hose to the valve below the water screen.
2. Close the valve *above* the water screen and open the valve *below* the water screen.
3. Turn on the water pump and pump 1/4 to 1/2 of the water from the reservoir, depending on the amount of scaling on the pads. Use a bucket or barrel to gauge gallons removed. A system with an 8" PIP drain trough holds approximately 1.2 gallons per foot of drain trough.

NOTE: To prevent pump damage, never allow reservoir to run dry.

4. After flushing the desired amount of water from the system, turn off the pump, close the lower valve, and open the upper valve to its previous setting.
5. Turn main water back on and allow the system to fill to the set water level.
6. Turn the water pump on and resume normal operation.

NOTE: To completely change the water, pump all water from the system, clean the reservoir, and refill to resume normal operation. **Do not allow the pump to run when reservoir is empty.**

Important Information

Consult the diagrams below and throughout this guide to better understand the assembly and installation of this evaporative cooling system. Diagrams are provided to be used as a general guide. Details specific to the actual structure the system will attach to may differ from what is shown.

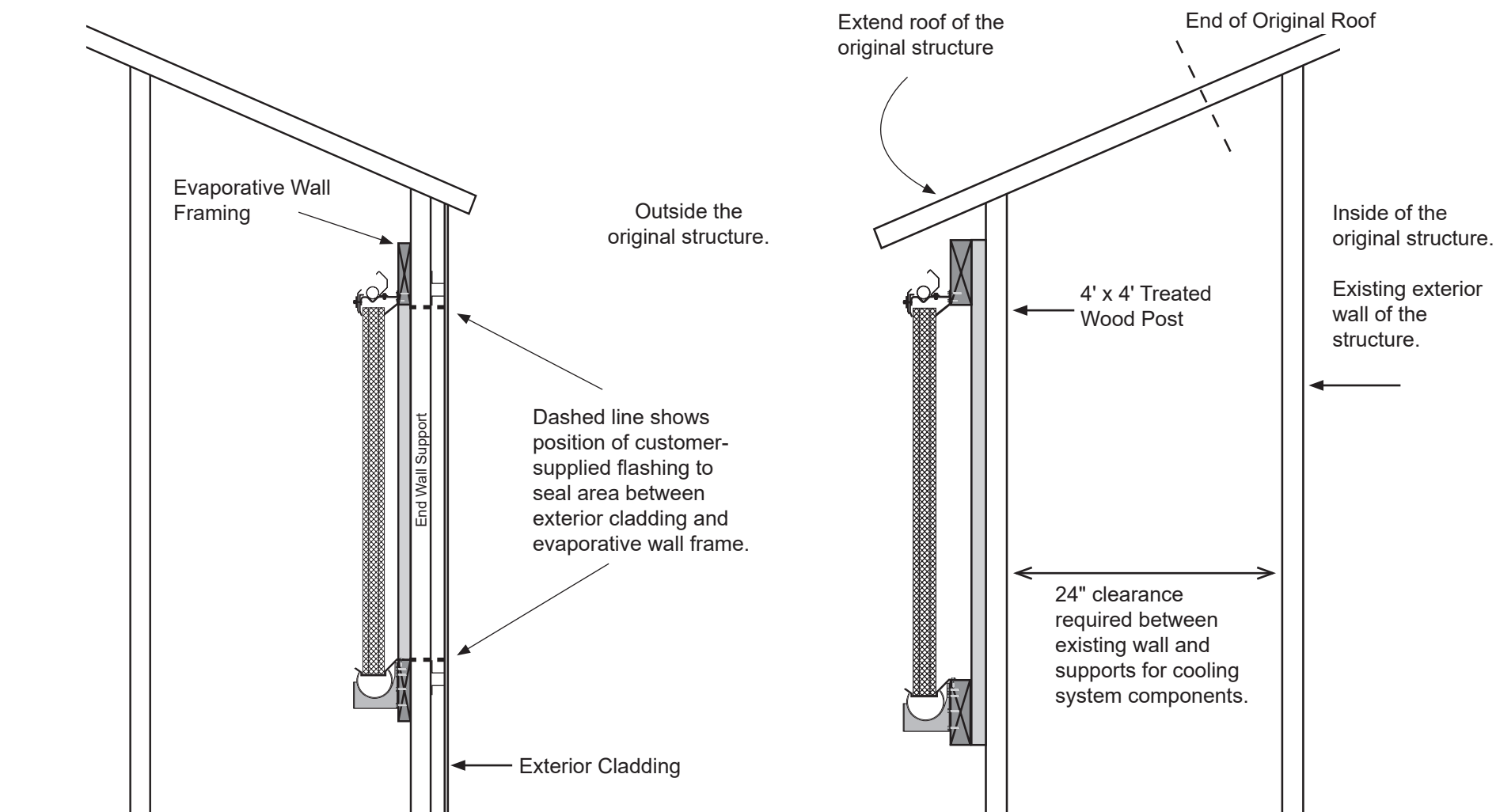

Cooling system mounted inside the structure — most greenhouse applications.

Cooling system mounted outside the structure. Ends to be enclosed to direct air flow through the cool cells.

Part Identification

PICTORIAL GUIDE

The following graphics and photos will help you identify the different parts of the evaporative cooling system. Consult the remainder of this guide for additional details and diagrams. (Some parts are not shown.) Diagrams are not to scale.

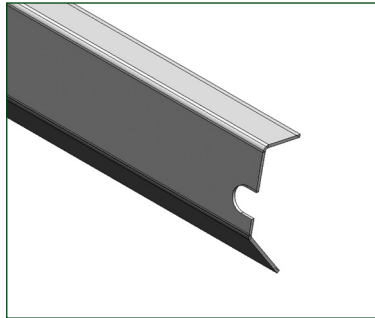

Front Panel — EVCxxxFP
(Actual part number depends on system length.)

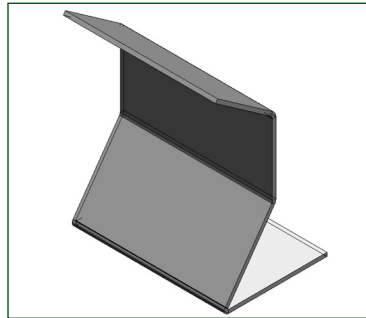

Deflector Splice Bracket—
EVCDFS001

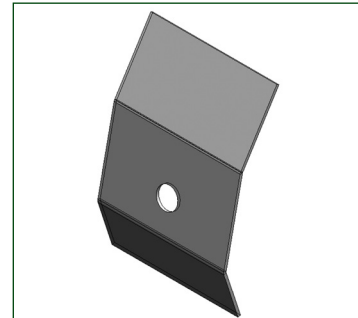

Front Panel Splice—
EVCFPS001

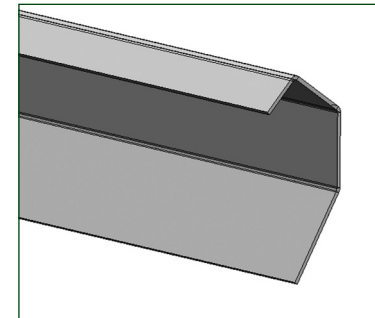

Deflector Shield — EVCxxxDF
(Actual part number depends on system length.)

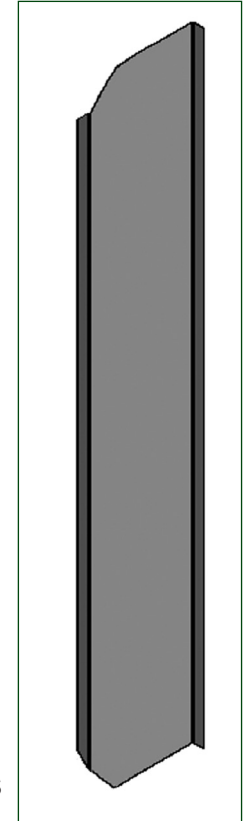

Universal Cooling Cell End Panel:
Dimensions depend on system cool cell height. Two (2) per system.

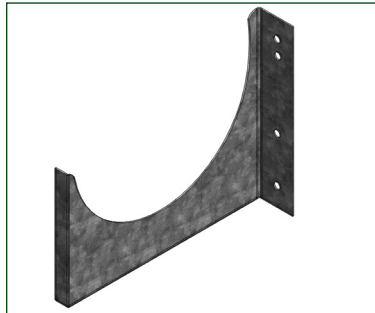

Bottom Bracket—EVCBBS002

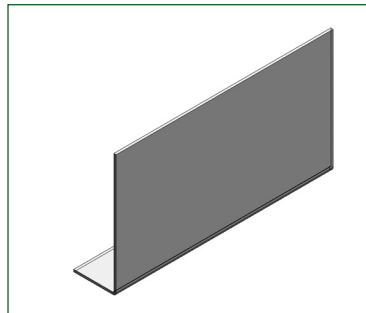

End Panel Bracket—
EVCEPB001

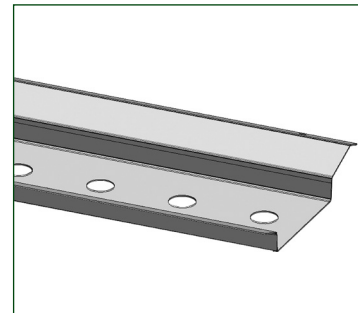

Drip Pan Tray—EVCxxxDPT
(Actual part number depends on system length.)

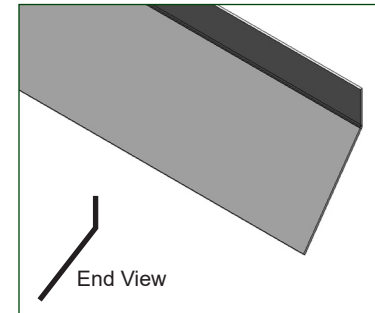

Back Pad Support —EVCxxxBPS
(Actual part number depends on system length.)

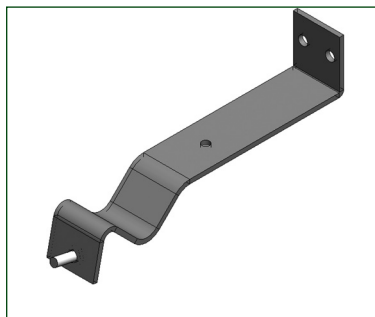

Top Bracket—EVCTB001B



Sump Pump—actual pump differs with the system.



FA2906 and
FA2902



112282
1/4" x 1" Lag
Screws

NOTE: The xxx shown in some part numbers represents the actual length of the part, which varies depending on the length of the system. For example, a part that is 60" long would show "060" as in EVC060DF.

Part Identification—continued

PICTORIAL GUIDE—continued



112285 (2)



111150 (1)



112298 (1)



WF2198



WF3511 (2)



WR1300 1" Valve (1)



WF2392 (1)



WF1540 (1)



WF1530 (2)



WF1982—Quantity depends on length of cooling system.



WF1574 (1)
WF6110 (1)



WF6777 (1)



WF6745 (1)



FAME16B



FALF15B



FAMF11B



FALF35B



FAME50B



FAG104B



WF3300 (1)



WF6990
PVC Cement
and
113372 Purple
Primer



FA4472B

PVC PRIMER & CEMENT

Follow all directions printed on pvc primer and cement containers. **Purple color of primer does not fade!** Use caution during application to reduce spills and over application at joints. **Prime all joints before assembly.**



WR1095 (1)
Tape



112604



WF1384

*Photos not to scale.

Assembly Instructions

1

CUSTOMER-SUPPLIED FRAMING

Using the diagrams and tables on this page, frame the rough opening for the cooling system. Read the following notes before you begin:

- For best results, use pressure-treated lumber to frame the opening. Check local codes for use restrictions in greenhouse environments.
- Attach stringers to building support posts using *customer-supplied fasteners*. **ATTENTION:** Brackets for cooling system are spaced at 5' on-center. Consider this dimension when attaching the stringers. Space the stringer fasteners so they will not interfere with the installation of the cooling system brackets. If fasteners will be positioned at the same spot, countersink them below the stringer surface.
- *Stringers to be installed level.* Upper and lower stringer can extend beyond rough opening to allow for the installation of water lines and electrical hookup. Stringer material that extends beyond rough opening can be cut to length after system is installed.

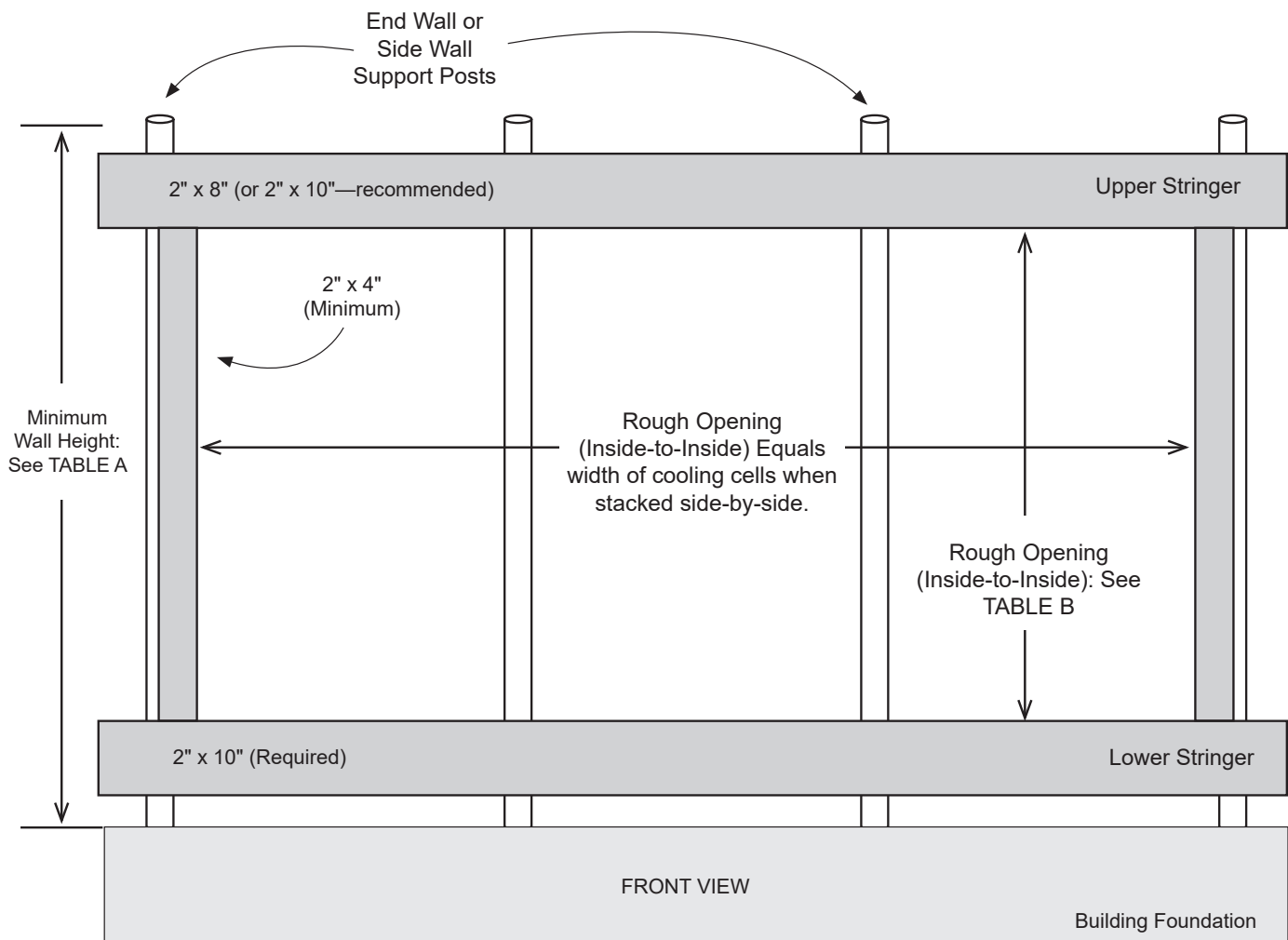

ATTENTION: Skip this page if you purchased a metal frame kit for your evaporative cooling system. Consult instructions included with kit and install frame according to those instructions. After installing metal frame kit components, continue with **Section 2** of this guide.

Consult technical drawings included with your building for additional installation details and clearances.

TABLE A: MINIMUM WALL HEIGHT

Pad Height	Minimum Wall Height
3'-0" (36")	4'-4" (52")
4'-0" (48")	5'-4" (64")
5'-0" (60")	6'-4" (76")
6'-0" (72")	7'-4" (88")

Minimum Wall Height = Pad Height + 16".

TABLE B: ROUGH OPENING HEIGHT

Pad Height	Clearance between top and bottom stringer.
3'-0" (36")	2'-11" (35")
4'-0" (48")	3'-11" (47")
5'-0" (60")	4'-11" (59")
6'-0" (72")	5'-11" (71")

Rough Opening Height = Pad Height - 1".

3

INSTALL BACK PAD SUPPORT AND BOTTOM BRACKETS

After constructing the rough opening for the system, install the Back Pad Support (**EVCxxxBPS**) and the Bottom Brackets (**EVCBBS002**). Secure these components to the stringers using the 112282 (1/4" x 1") lag screws. Read these notes before proceeding:

- Use a drill and a 1/8" drill bit to drill the pilot hole for the 1/4" lag screws—recommended.
- Butt the ends of the individual back pad supports together and secure to stringer. Do not overlap ends.
- Snap chalk lines along the stringers to install back pad support sections and bottom brackets level.
- See Table C and other diagrams to properly space and install the bottom brackets (EVCBBS002). If metal frame kit was purchased, install the gussets *after* installing the bottom brackets. **See Gusset Installation Note in the Frame Kit instructions.**

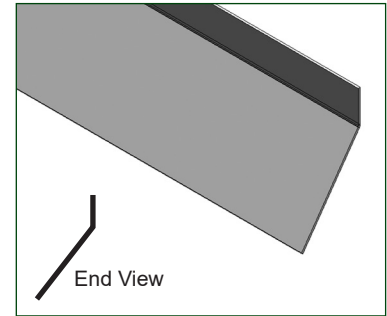

Back Pad Support—**EVCxxxBPS**
(Actual part number depends on system length.)



Bottom Bracket—**EVCBBS002**

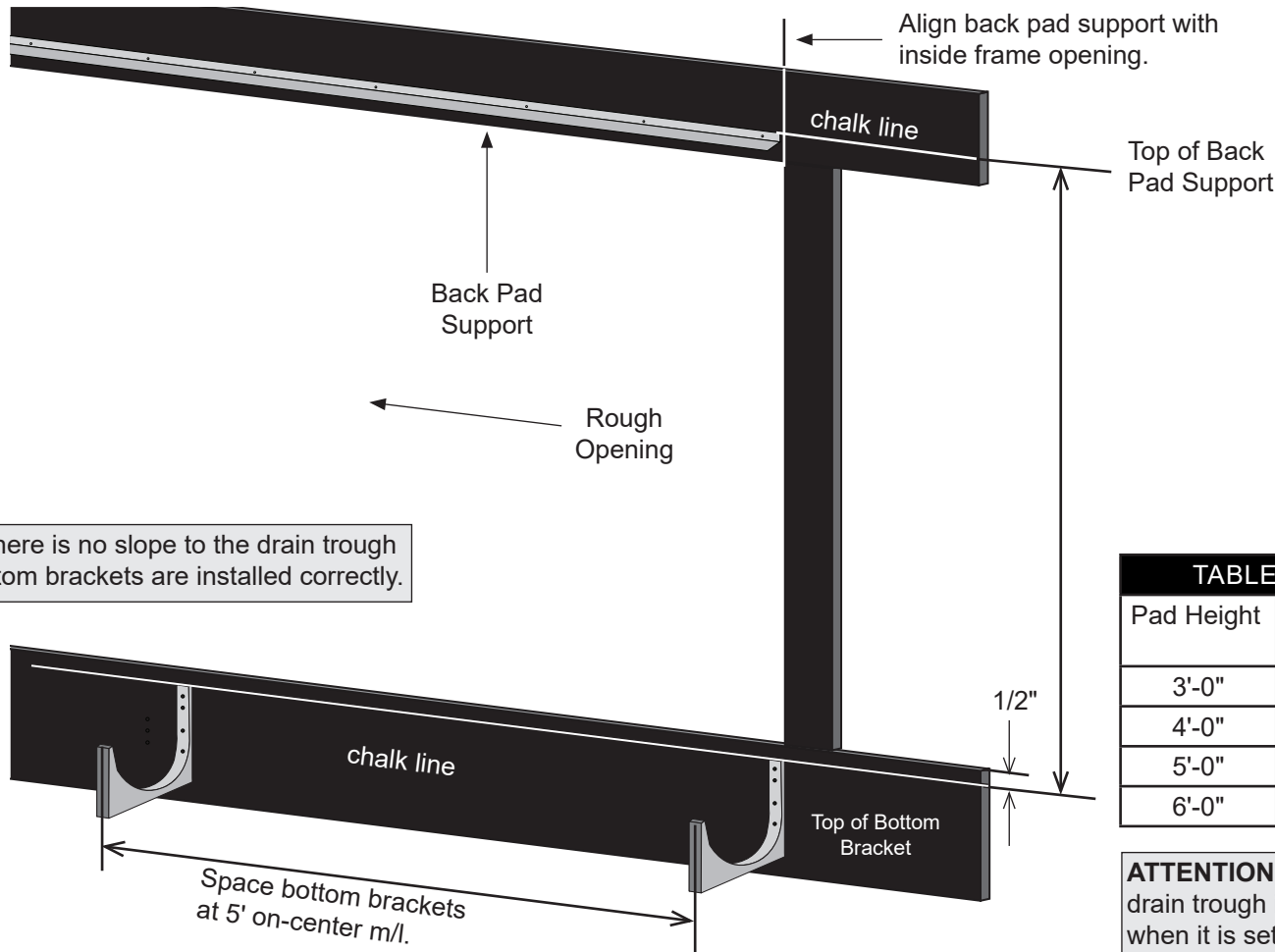

NOTE: There is no slope to the drain trough when bottom brackets are installed correctly.

TABLE C: ROUGH OPENING HEIGHT	
Pad Height	Distance between top of bottom bracket and top of back pad support.
3'-0"	3'-1/2" (36.5")
4'-0"	4'-1/2" (48.5")
5'-0"	5'-1/2" (60.5")
6'-0"	6'-1/2" (72.5")

ATTENTION: Install all bottom brackets level so drain trough is level throughout the length of system when it is set into the bottom brackets.

3

INSTALL BACK PAD SUPPORTS AND BOTTOM BRACKETS: Additional Diagrams—continued

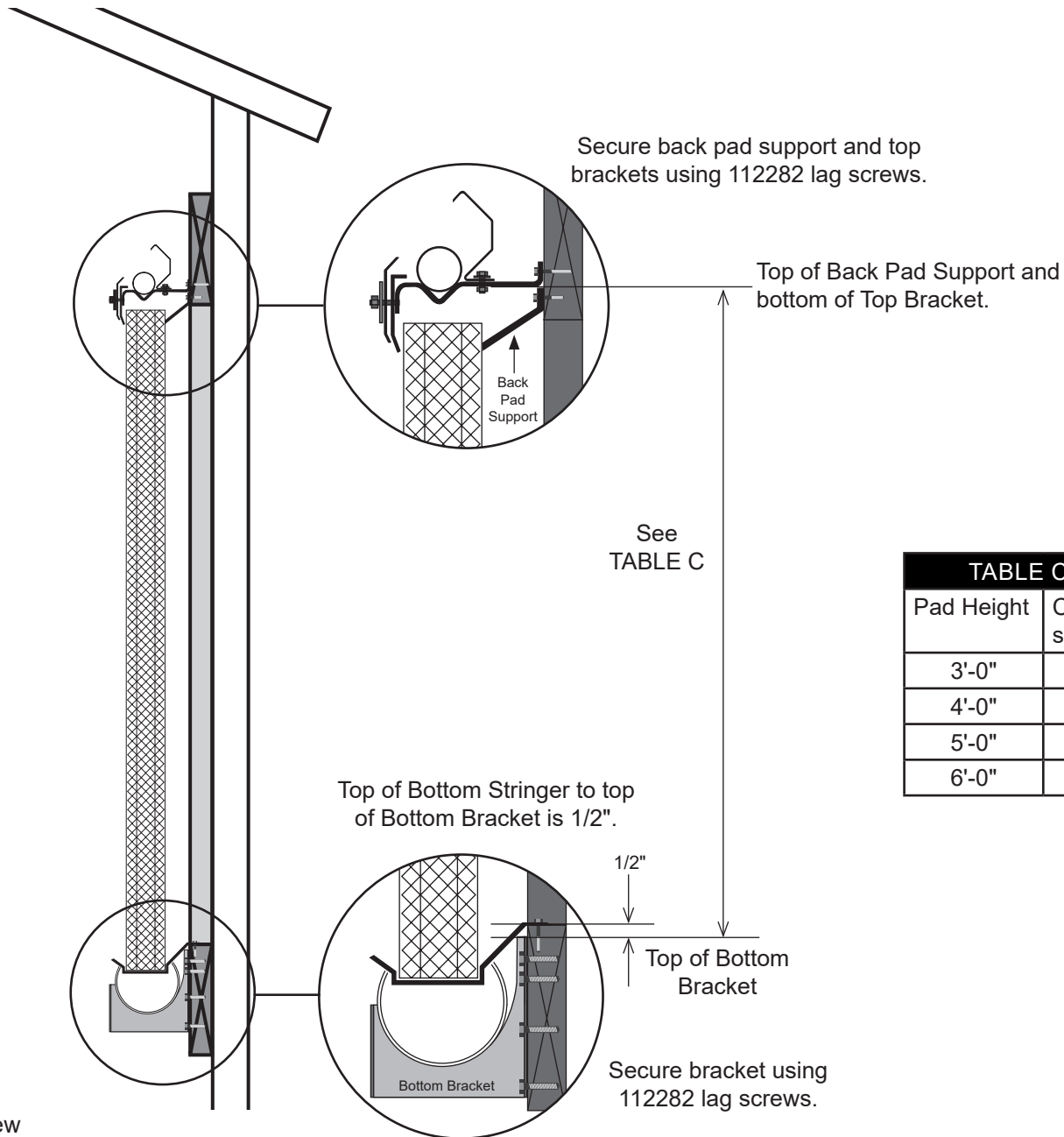

TABLE C: ROUGH OPENING HEIGHT	
Pad Height	Clearance between top of back pad support and top of bottom bracket.
3'-0"	3'-1/2" (36.5")
4'-0"	4'-1/2" (48.5")
5'-0"	5'-1/2" (60.5")
6'-0"	6'-1/2" (72.5")

4

INSTALL TOP BRACKETS

Consult the diagrams on this page to install the top brackets. Read the following notes before you proceed:

- Use a drill and a 1/8" drill bit to drill the pilot hole for the 1/4" lag screws—recommended.
- Space all interior top brackets, those between the top brackets at each end, at 5' on-center.
- Consult the diagrams to set the end top bracket when you begin.
- Mount top brackets directly above the back pad support. Use the support to maintain alignment of brackets. See diagram on previous page.

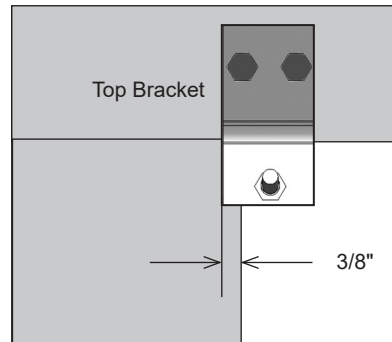

Diagram A: Front View of Top Bracket.
Back pad support is not shown.

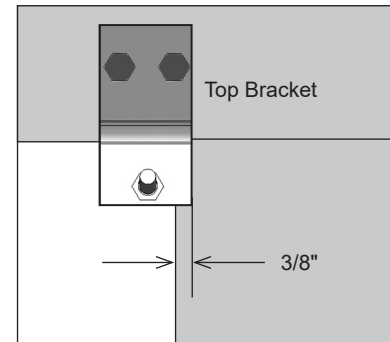
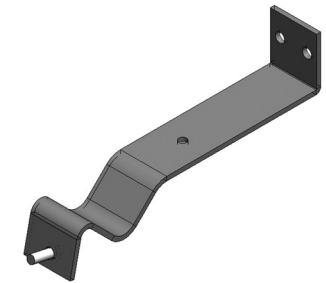
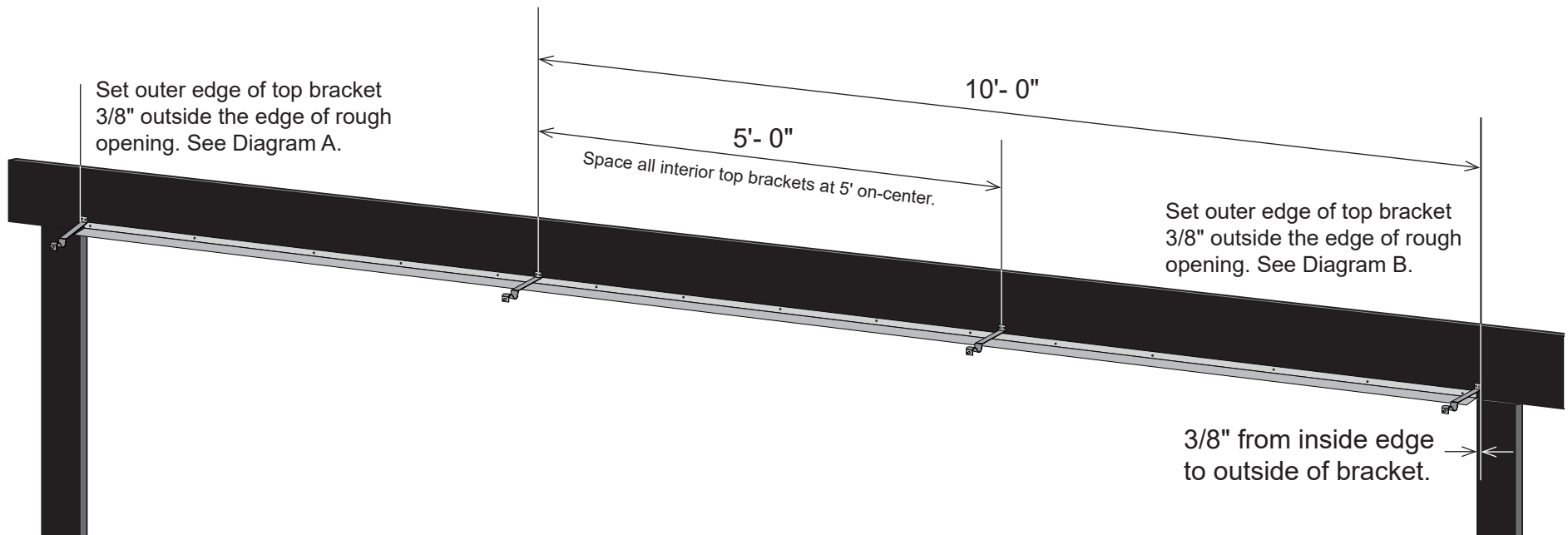

Diagram B: Front View of Top Bracket.
Back pad support is not shown.



Top Bracket—EVCTB001B
Secure to stringer using
112282 lag screws.



5

INSTALL DEFLECTOR SPLICE BRACKETS AND DEFLECTOR SHIELD

Attach Deflector Splice Brackets (EVCDFS001) to the top bracket and attach Deflector Shield (**EVCxxxDF**) to splice brackets. Read the following notes before you begin:

- Attach one deflector splice bracket to each top bracket using 1/4" bolts, nuts, and washers. See exploded end view below.
- Attach the deflector shield to the deflector splice using FA4472B Tek screws and 5/16" x 2-9/16" magnetic nut setter. Brace the splice bracket with a block of wood during Tek screw installation to prevent bending of the bracket. Clamp the deflector to the bracket with locking pliers for easier installation of the Tek screws.
- Butt the ends of each deflector shield together when attaching them to the splice brackets. Do not overlap the ends.



FAME16B



FALF15B



FAMF11B



FAG104B



FA4472B

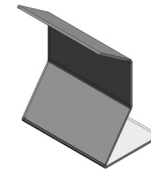

Deflector Splice Bracket—
EVCDFS001

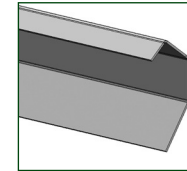

Deflector Shield—
EVCxxxDF
depending on
system length
and design.

Exploded End View

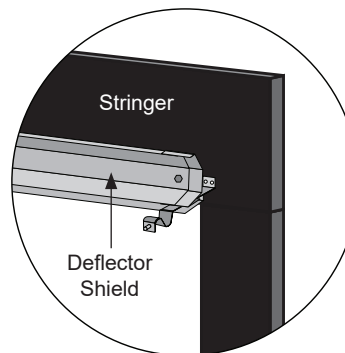
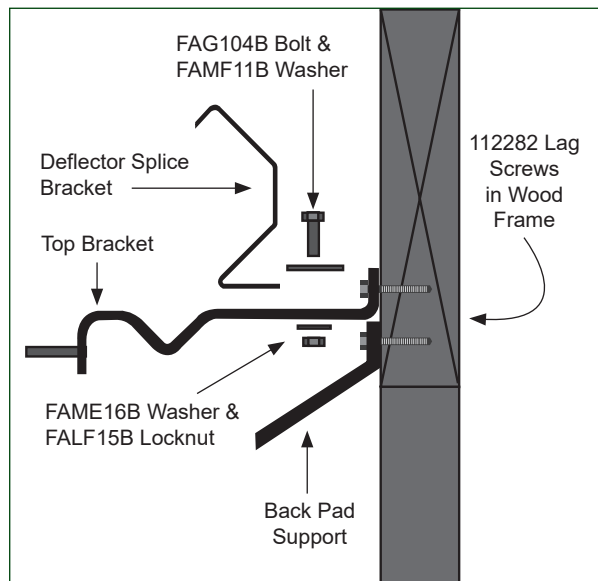

The above diagram shows a deflector splice bracket attached to an end top bracket.

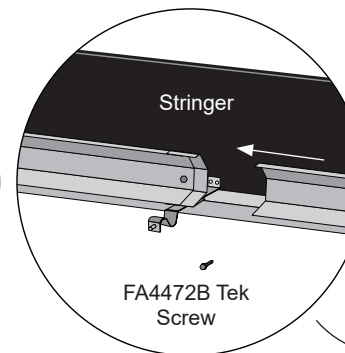

The above two diagrams show a deflector splice bracket attached to an interior top bracket where two separate deflector shields meet. Use the FA4472B Tek screws to secure all deflector shields to the deflector splice bracket.

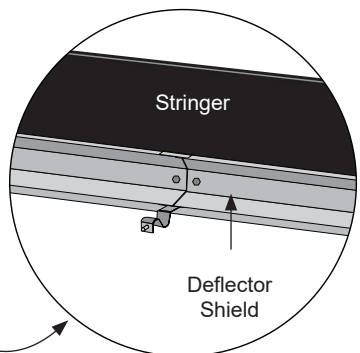

6

PREPARE TROUGH FOR DRIP PAN TRAY INSTALLATION

Complete these steps to prepare the trough assembly for installation:

1. With assistance, set the trough assembly in the bottom brackets attached to the wood frame.
2. Determine at which end the reservoir will be located. Verify plain end of drain trough is oriented towards reservoir.
3. Adjust assembly as needed to prevent coupler(s) (or belled end of pipe) from interfering with bottom brackets. Couplers or pipe joints should not touch any bottom bracket. Main 8" PIP must be saddled in each bottom bracket for proper drainage and final assembly.

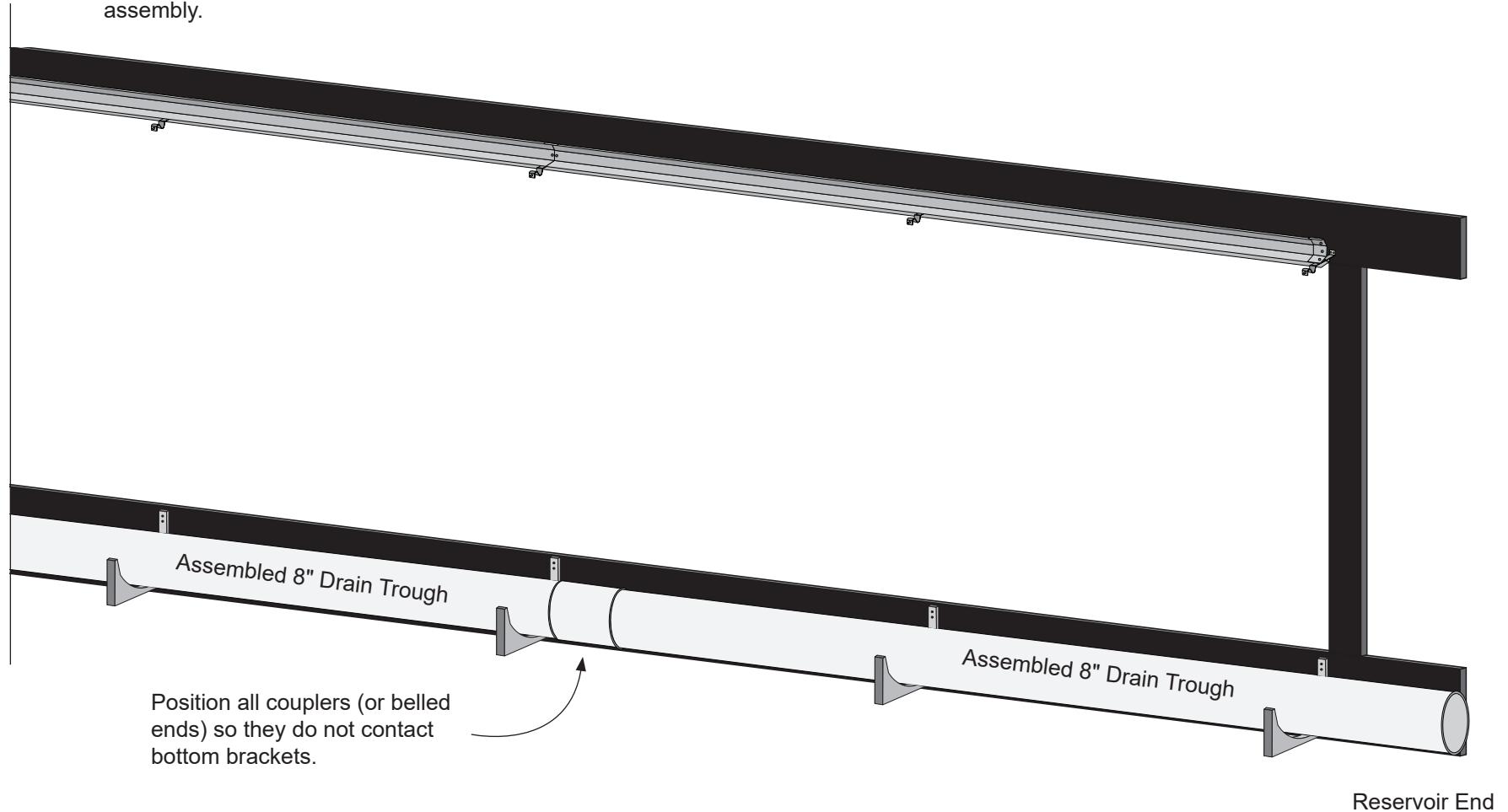

NOTE: There is no slope to the drain trough when bottom brackets are installed correctly.

6

PREPARE TROUGH FOR DRIP PAN TRAY INSTALLATION—continued

4. Verify that the trough assembly extends far enough beyond the frame at the reservoir end to reach the reservoir once it is set in place. Minimum length is 12".
5. Using the rough opening of the frame as a guide, mark the length of the evaporative cooling system plus 1/2" inch (1/4" beyond the opening at each end) on the top of the 8" trough. See diagram below.
6. Using a drill and 1/2" bit, drill a hole at each corner. See diagram. **Use a twist drill bit; do not use a spade bit.**
7. With an assistant, take a circular saw equipped with a blade for cutting plywood and make the long side cuts to each end. During the cut do not allow the material to sag into the pipe. Wedge wood shims in the cut as needed to prevent the blade from binding.
8. Use a jig saw to make clean end cuts and to finish the long cuts.
9. Remove all loose material and thoroughly clean the drain trough.

IMPORTANT: Any material left in the drain tube will wash through the system and ultimately clog the water screen, header pipe outlets, and may damage the pump and related valves. You must clean the drain trough before continuing with this procedure.

10. After cleaning the trough, place it in the bottom brackets (if it was removed for cutting) and continue with the next procedure.

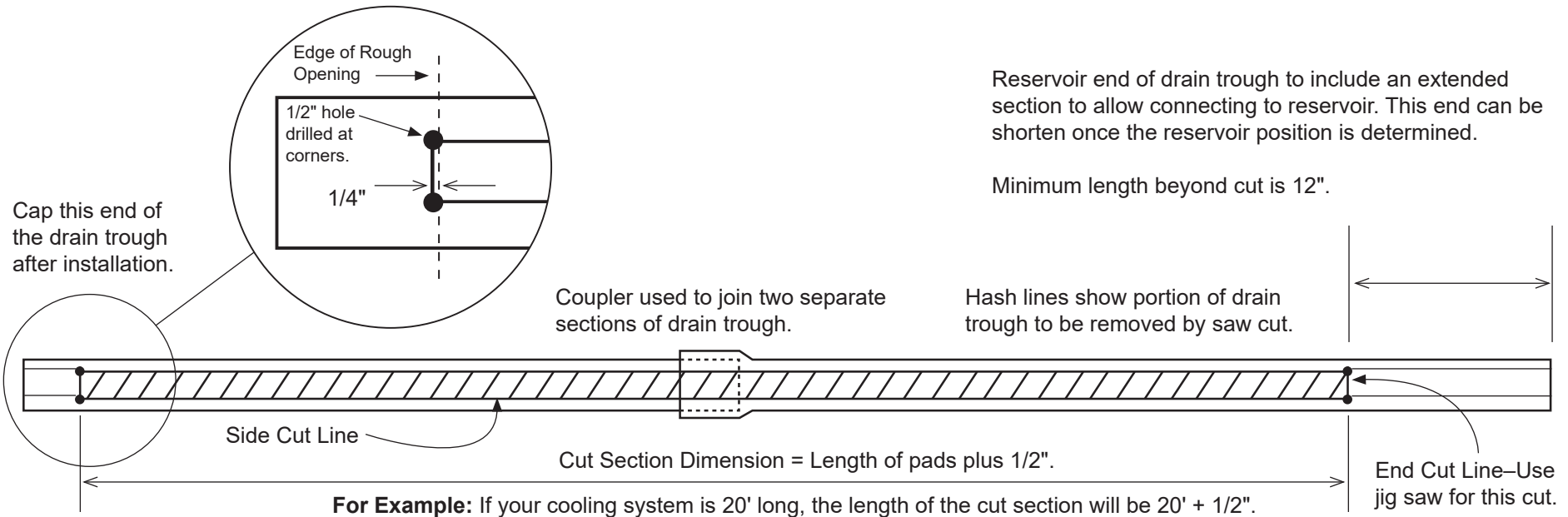

7

PLACE DRIP PAN TRAY IN DRAIN TROUGH

With the drain trough in place, install the drip pan tray (or trays). Read the following notes before you begin:

- Secure the individual tray sections to the bottom stringer using the 112282 lag screws.
- For multiple tray sections, butt the ends together. *Do not overlap ends.*
- Use a flat screwdriver when installing the trays. An assistant is helpful. See diagrams below.
- When installed correctly, trays will align with the rough opening of the treated-wood frame.
- Cut and remove belled end of PVC from the non-reservoir end of the drain trough.
- Prime and cement the 112761 end cap to the 8" drain trough.



112282
1/4" x 1" Lag Screws

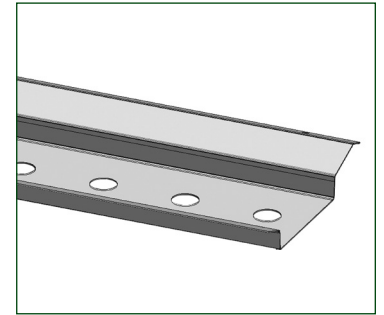

Drip Pan Tray—**EVCxxxDPT**
depending on system length and design.

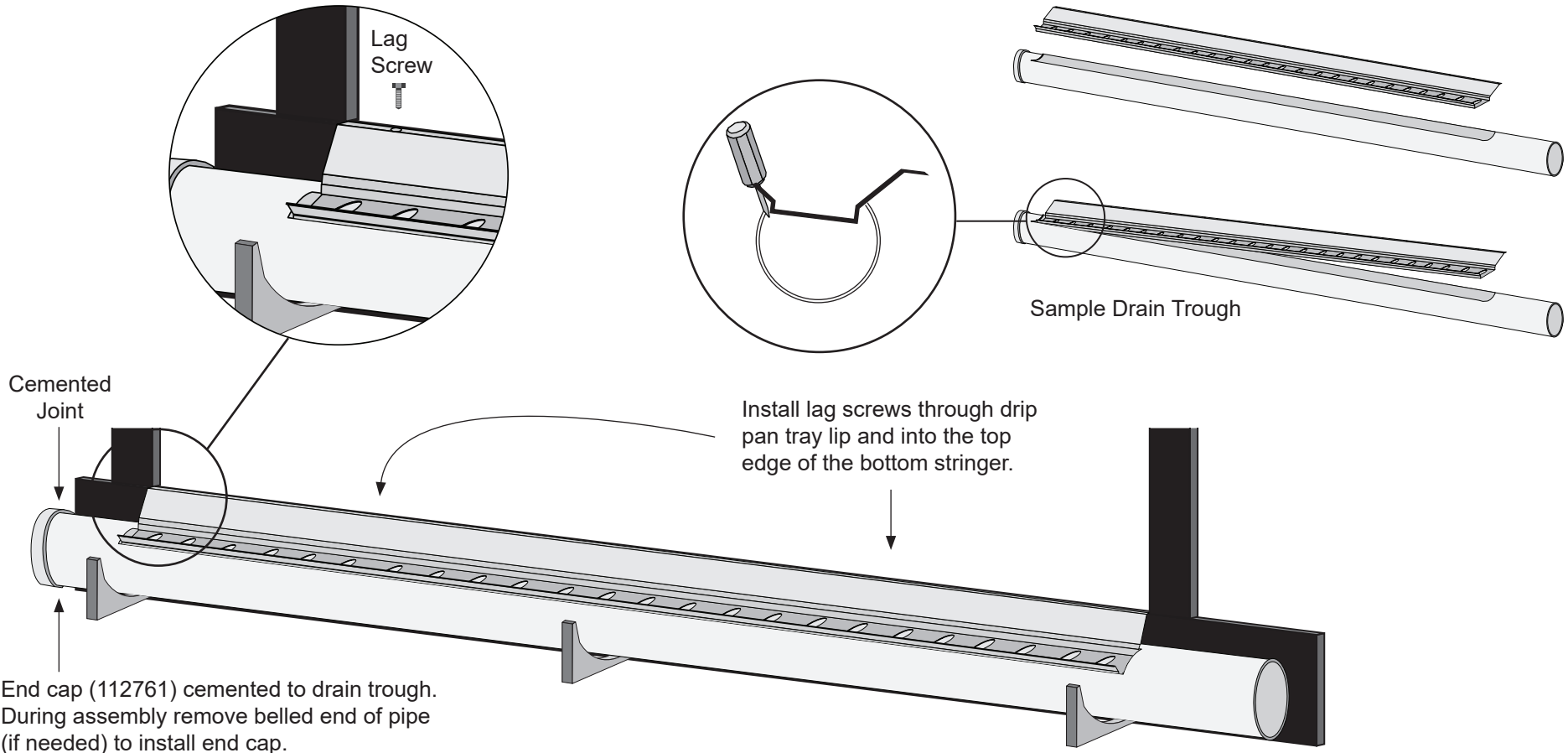

8

INSTALL END PANEL BRACKETS

With the drip pan trays installed, attach the end panel brackets. Read these notes before you begin:

- Attach end panel brackets to the drip pan tray at each end of the drain trough.
- Use FA4472B Tek screws to secure end panel brackets to the drip pan tray.
- Align brackets with the rough opening of the frame.
- End panel attaches to the outside of the end panel bracket. Ensure there is enough clearance between bracket and drain trough.



FA4472B

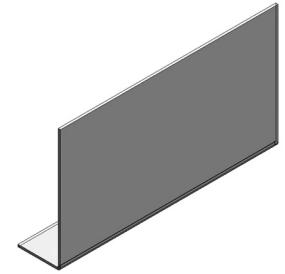

End Panel Bracket—
EVCEPB001 (2)

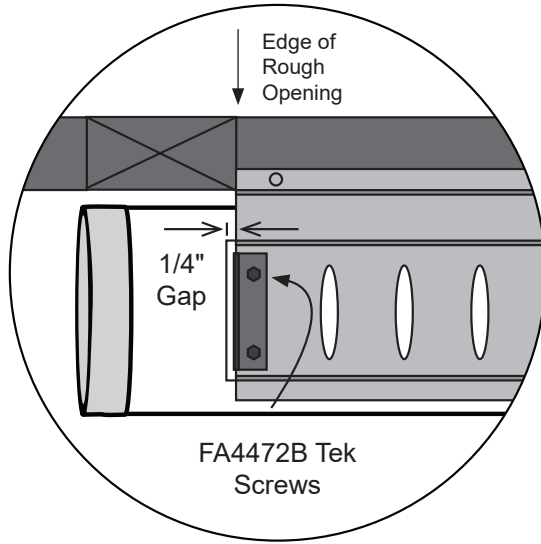

TOP VIEW

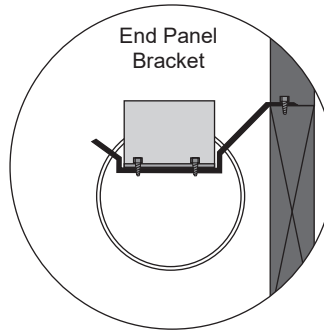

Cross Section View

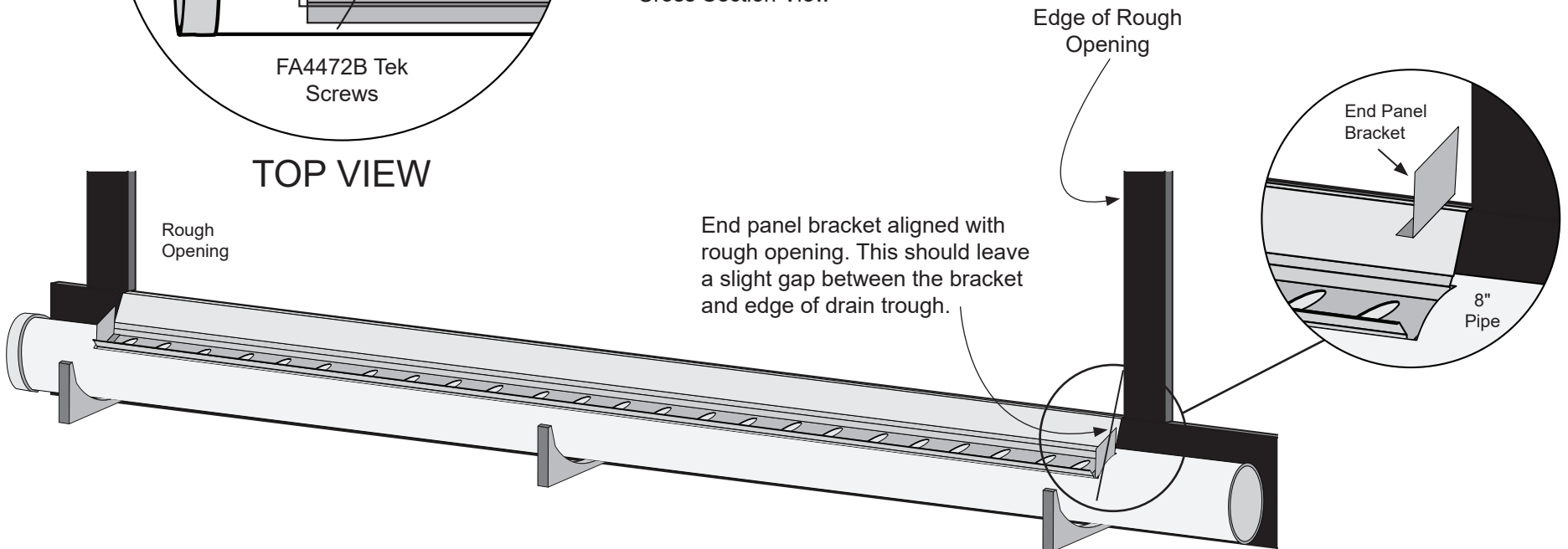

9

INSTALL END PANELS

Install the two end panels. Read these notes before you begin:

- Secure each end panel to the wood frame using the 112282 lag screws. Drill pilot hole for screws as previously suggested.
- Secure each end panel to the end panel bracket using two (2) FA4472B Tek screws.

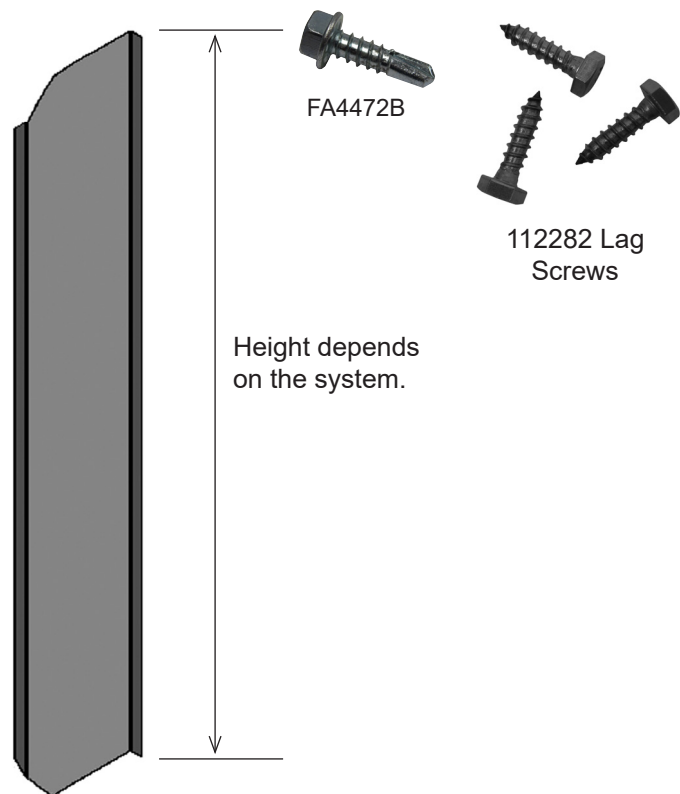

Universal Cooling Cell
End Panel: Dimensions
depend on system cool
cell height.

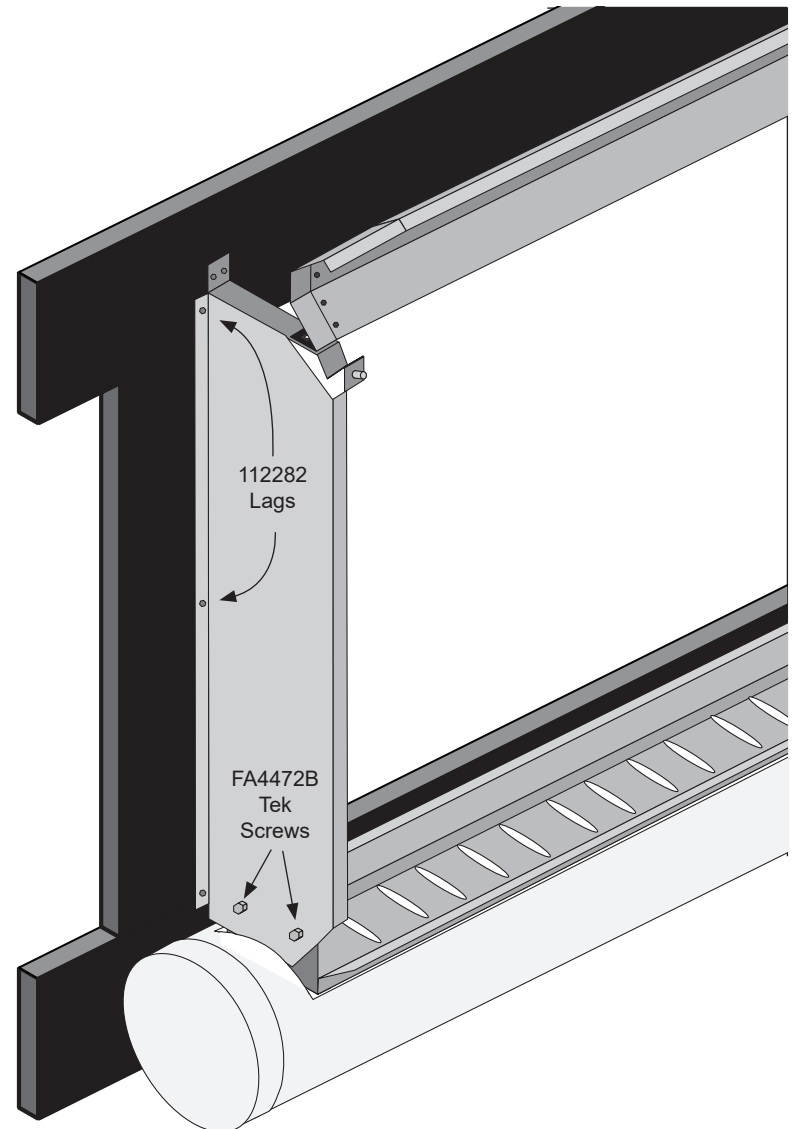

10

ASSEMBLE SUPPLY HEADER AND PLACE ON TOP BRACKETS

Complete these steps:

1. Locate the individual header tubes and WF1982 couplings for 1-1/2 pvc pipe. All header tubes include pre-drilled holes evenly spaced throughout the length of the tube.
2. Align all spray holes and connect the tubes using WF1982 couplings and FA4472B Tek screws. **DO NOT USE CEMENT TO SECURE THE CONNECTION.** Drive Tek screws as shown through each coupling and into the header tubes. Do not strip the threads in the pvc pipe.
3. With assistance, set the assembly in place on the top brackets and adjust its position. For lengths greater than 25', set the header tubes in place on the support brackets and assemble.



ATTENTION: See Step 6 (next page) to install plug, tee, valve, and Tubes A & B in this location.

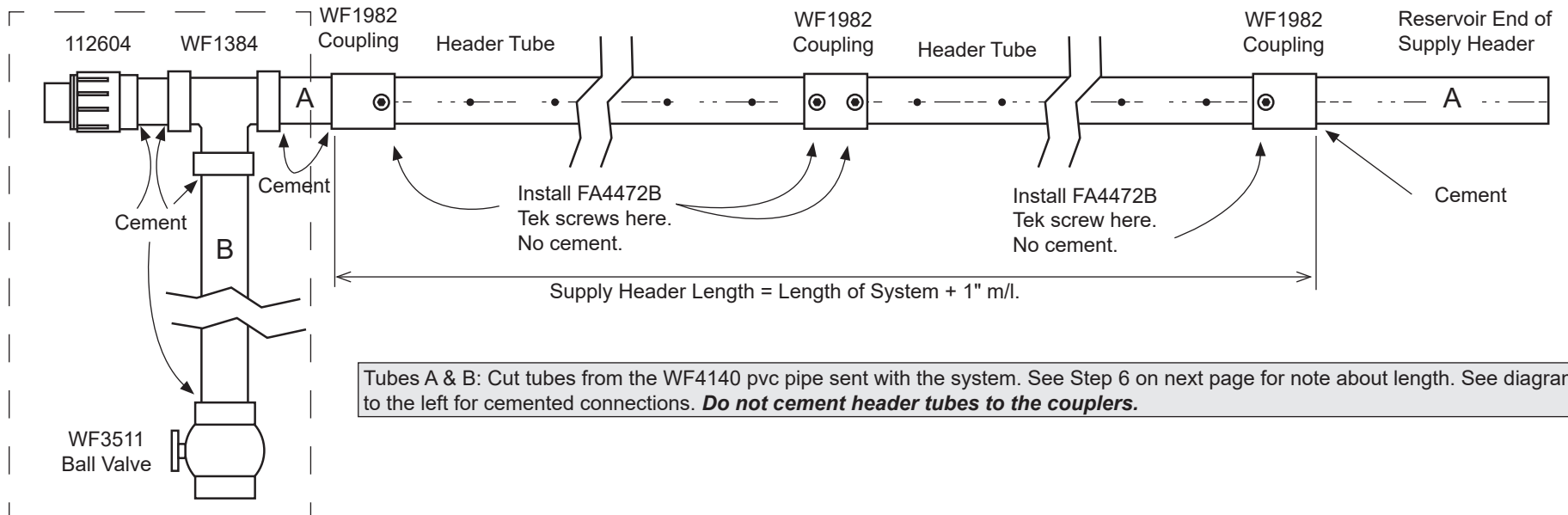

10

ASSEMBLE SUPPLY HEADER AND PLACE ON TOP BRACKETS—continued

4. Move to the reservoir end of the supply header and check the positions of the first spray hole in the tube and the end top bracket. The first hole **at each end** must be at least 4" in from the end of the deflector shield. See Figure 1.

NOTE: It may be necessary to cut the header tube and add an extension tube using a piece of the WF4140 and a WF1982 coupling. Positioning the spray hole too close to the end of the deflector will cause water to spray outside the system during operation.

5. Using the diagrams below, rotate the supply header as needed to set the 45° angle of the spray holes. Water sprays back toward the deflector shield when system is in operation. See Figure 2.
6. At the end **opposite the reservoir position**, install extension tubes (A & B), WF1384 Tee Fitting, 112604 Clean Out Adapter, and the WF3511 ball valve as shown. Prime and cement those connections as shown on previous page. **IMPORTANT:** Keep length of Tube A as short as possible to allow easier access to clean out plug. Length of Tube B is left to the discretion of customer. Secure this entire assembly to the frame to prevent damage to supply manifold and related fittings and brackets. **Verify that the 45° angle of spray holes is maintained.**
7. Continue with the installation of the cool pads.

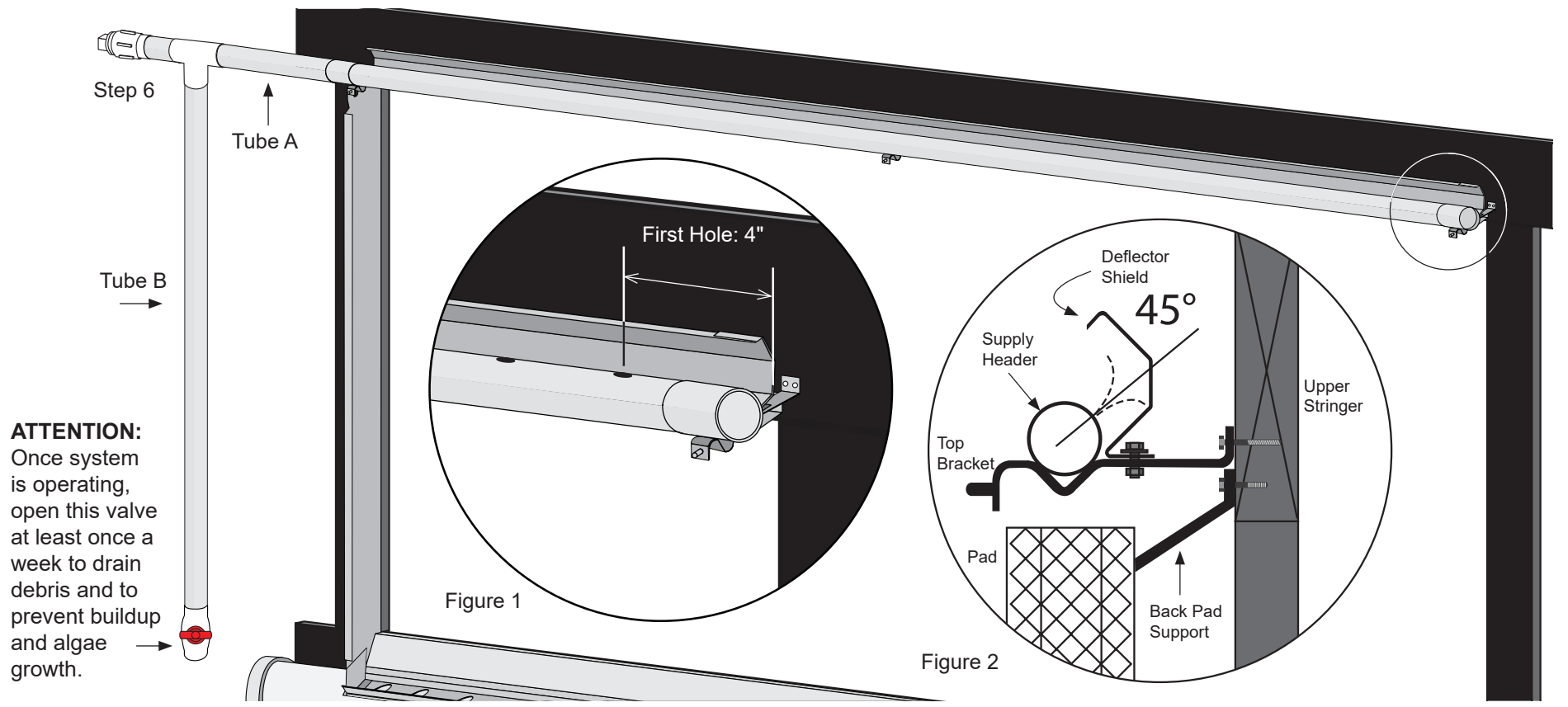

ATTENTION: Once system is operating, open this valve at least once a week to drain debris and to prevent buildup and algae growth.

11

INSTALL COOLING PADS AND FRONT PANEL

Complete these steps to install the individual cooling pads:

1. Read and follow the instructions for pad installation supplied *with the cooling pads*.
2. Beginning at one end, slide the first panel into place behind the lip of the end panel. **Verify that you have installed the pad according to the instructions supplied with the cooling pads.**
3. Continue adding cooling pads and work toward the other end of the cooling system.
4. Take next to last cooling pad and slide it into place behind the lip of the end panel.

NOTE: The front panels and front panel splices can be installed as pads are set into position, or these can be installed after all pads are in place. See the next page for the installation steps for front panel and front panel splices.

5. Place the last pad into position. Adjust the positions of the pads as needed to achieve the desired fit.



Photo shows instruction sticker affixed to pad.

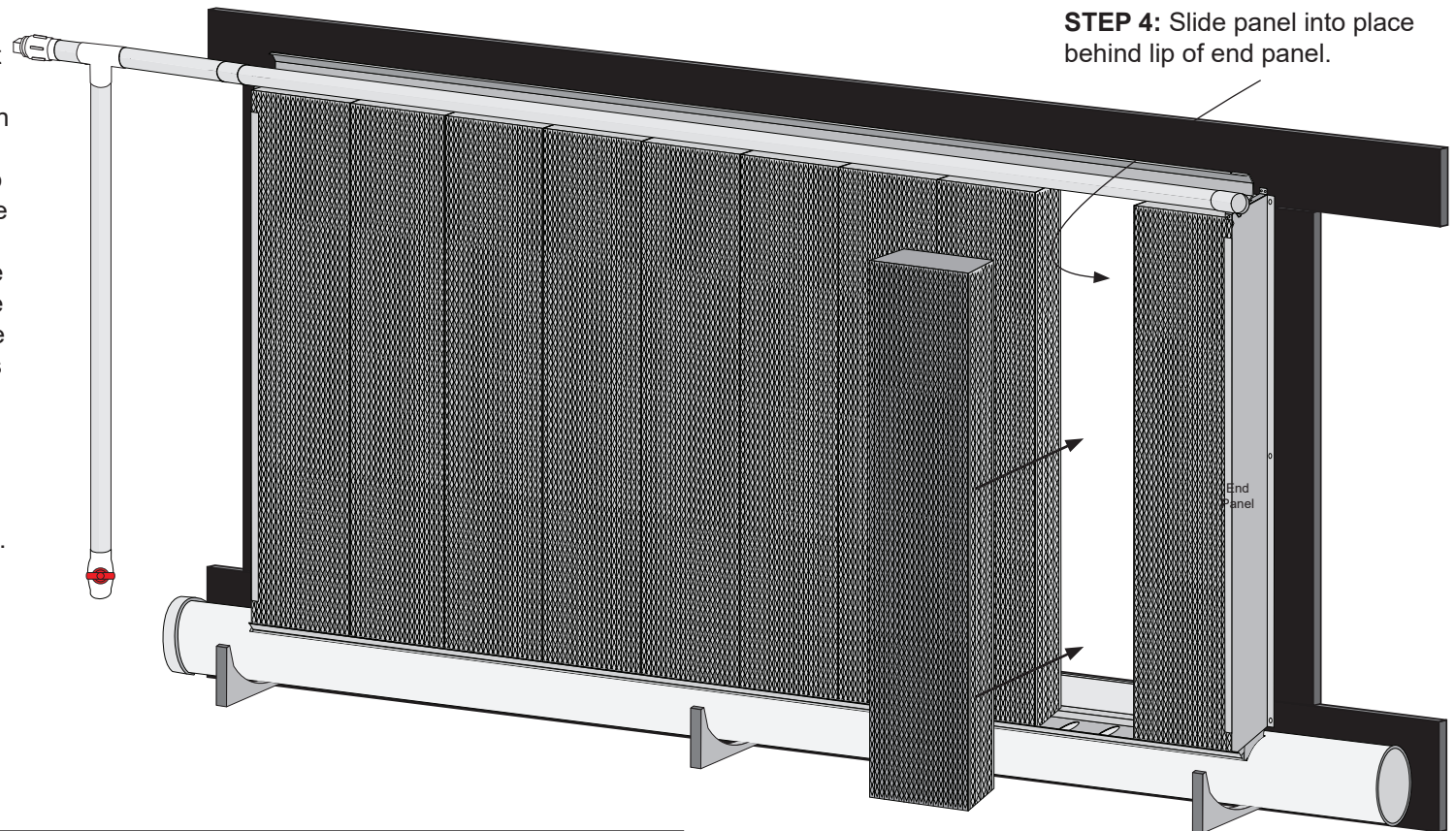

STEP 4: Slide panel into place behind lip of end panel.

ATTENTION: Install all cooling pads according to the instructions sent with those cooling pads. Diagram shows the customer-supplied wood frame.

Reservoir Position

11

INSTALL COOLING PADS AND FRONT PANEL—continued

6. To secure the cooling pads in place, attach the front panel(s) and front panel splice(s) to the top brackets using 1/4" fender washers (FAMF11B) and 1/4" lock nuts (FALF15B).

NOTE: Cooling systems typically include multiple front panels. During installation, butt the ends of the front panels together and install a front panel splice at each top bracket where two front panels meet. Do not over-tighten the lock nuts. Tighten until snug. Install front panel splices only at the joints where two front panels meet.

7. Continue with the installation of the reservoir and related plumbing for the main water supply.

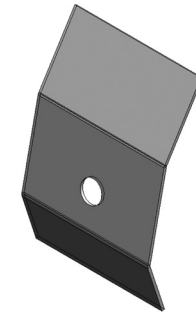

Front Panel Splice—**EVCFPS001**

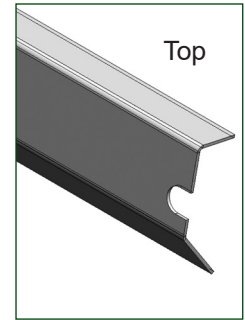

Front Panel—**EVCxxxFP** depending on system length.

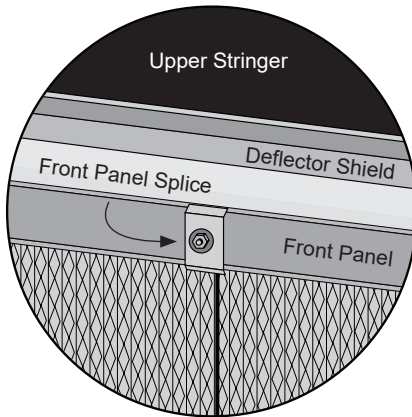

A: Install front panel splice at the joint where two front panels meet. Attach using FAMF11B washer and FALF15B nut.

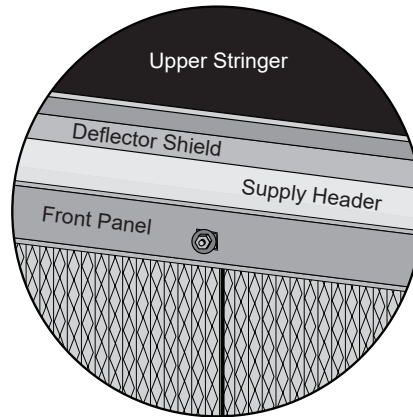

B: Install a FAMF11B washer and FALF15B nut between front panel ends. *Do not install a front panel splice at this connection.*

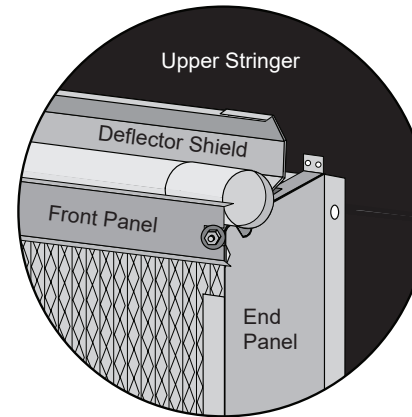

C: Install a FAMF11B washer and FALF15B nut at panel ends. *Do not install a front panel splice at this connection.*



FAMF11B



FALF15B

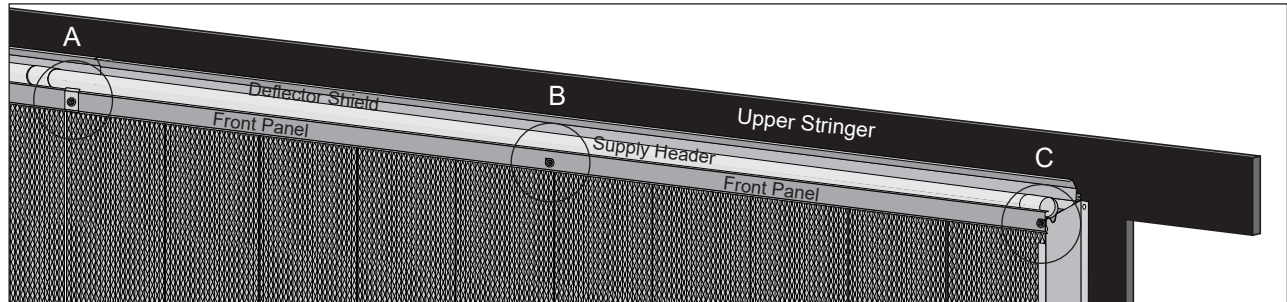
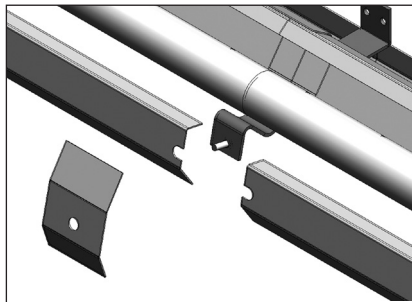

12

INSTALL RESERVOIR AND RELATED PLUMBING

Once the main cooling system is assembled, install the reservoir, water pump, and related plumbing. Consult the diagrams on the following pages and the parts shown on pages 6 and 7 for part identification.

1. First, prepare a solid and level foundation for the reservoir. Dry fit the reservoir to the outlet end of the drain trough. Cut the end of the 8" trough if needed to allow reservoir to sit in desired location. Do not set reservoir too close to cooling pads. Allow room for cleaning and maintenance. **Consult technical drawings for proper clearances if building is equipped with a blackout system.**
2. Clean drain trough end. Apply primer and cement and slide reservoir onto pipe and into place. Allow cement to set. Verify that cement is evenly applied and wipe away excess cement from joint.

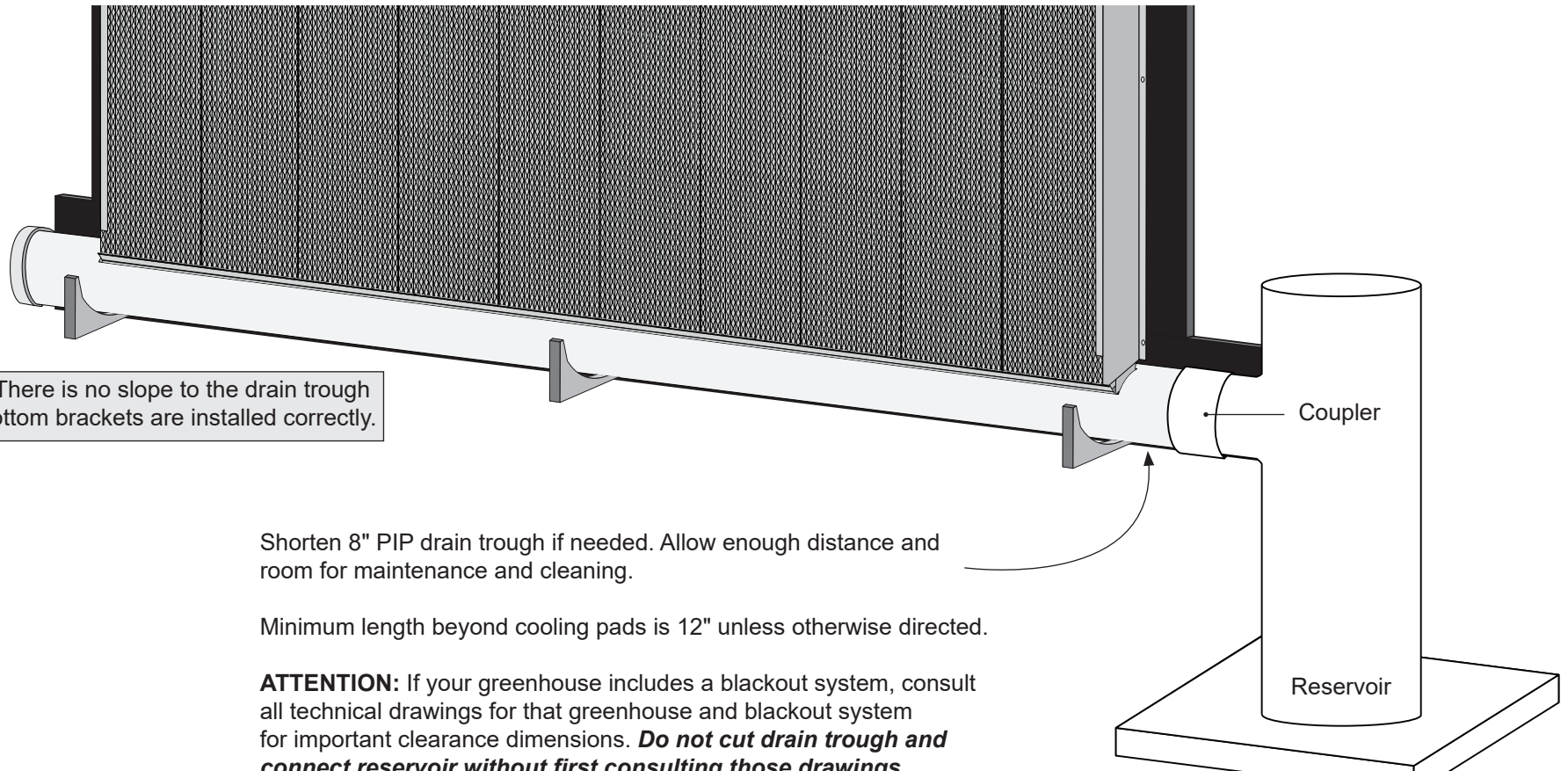

NOTE: There is no slope to the drain trough when bottom brackets are installed correctly.

Shorten 8" PIP drain trough if needed. Allow enough distance and room for maintenance and cleaning.

Minimum length beyond cooling pads is 12" unless otherwise directed.

ATTENTION: If your greenhouse includes a blackout system, consult all technical drawings for that greenhouse and blackout system for important clearance dimensions. **Do not cut drain trough and connect reservoir without first consulting those drawings.**

Clean surfaces after dry fitting the reservoir to drain trough. Apply pvc primer and cement, slide reservoir into place, and wipe excess cement. Allow to dry.

Provide a solid, level surface for the reservoir. A concrete pad or floor, concrete patio stones, crushed rock, or treated wood blocks are all acceptable.

12

INSTALL RESERVOIR AND RELATED PLUMBING—continued

3. Continue with the assembly of the remaining water supply plumbing. Consult the diagrams below and on the next page for details.

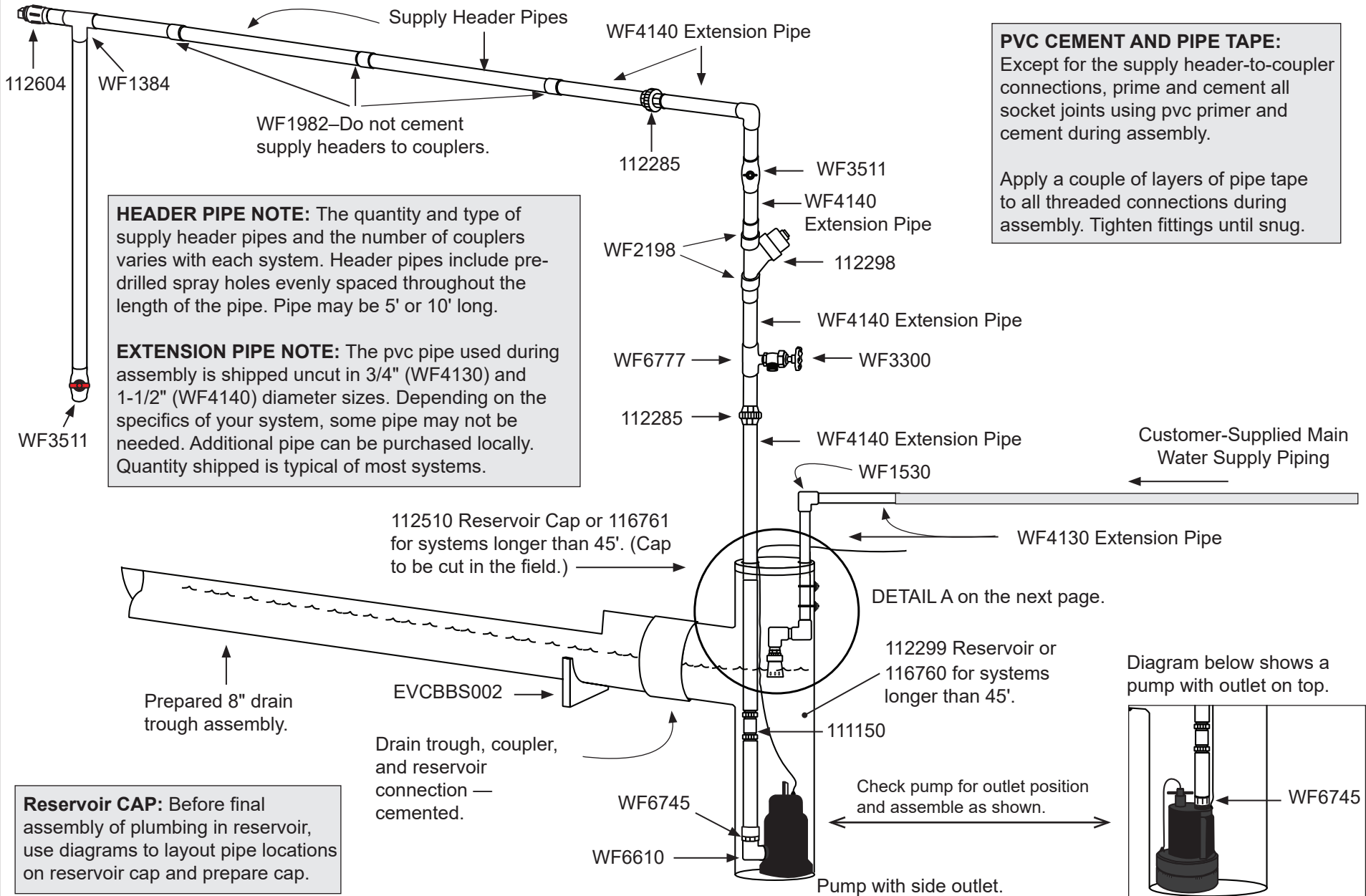

PVC CEMENT AND PIPE TAPE:
Except for the supply header-to-coupler connections, prime and cement all socket joints using pvc primer and cement during assembly.

Apply a couple of layers of pipe tape to all threaded connections during assembly. Tighten fittings until snug.

HEADER PIPE NOTE: The quantity and type of supply header pipes and the number of couplers varies with each system. Header pipes include pre-drilled spray holes evenly spaced throughout the length of the pipe. Pipe may be 5' or 10' long.

EXTENSION PIPE NOTE: The pvc pipe used during assembly is shipped uncut in 3/4" (WF4130) and 1-1/2" (WF4140) diameter sizes. Depending on the specifics of your system, some pipe may not be needed. Additional pipe can be purchased locally. Quantity shipped is typical of most systems.

Reservoir CAP: Before final assembly of plumbing in reservoir, use diagrams to layout pipe locations on reservoir cap and prepare cap.

12

INSTALL RESERVOIR AND RELATED PLUMBING — continued

Diagram below shows how to assemble the main water supply shutoff valve and how it is attached to the reservoir. Use the u-bolt to mark the hole positions on the reservoir. Use a drill and 1/4" drill bit to drill through the reservoir wall. Assemble the valve and pvc fittings and attach to reservoir. Drill all holes above the water line. Water level will be below the top edge of the cutout in the drain trough.



VALVE INSTALLATION & OPERATION

For information go to the following website:
<http://hudsonvalve.com/troubleshooting>

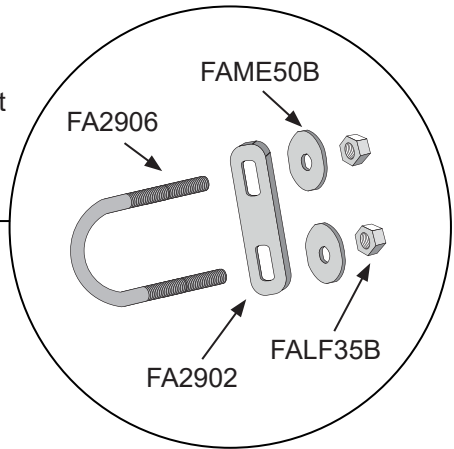
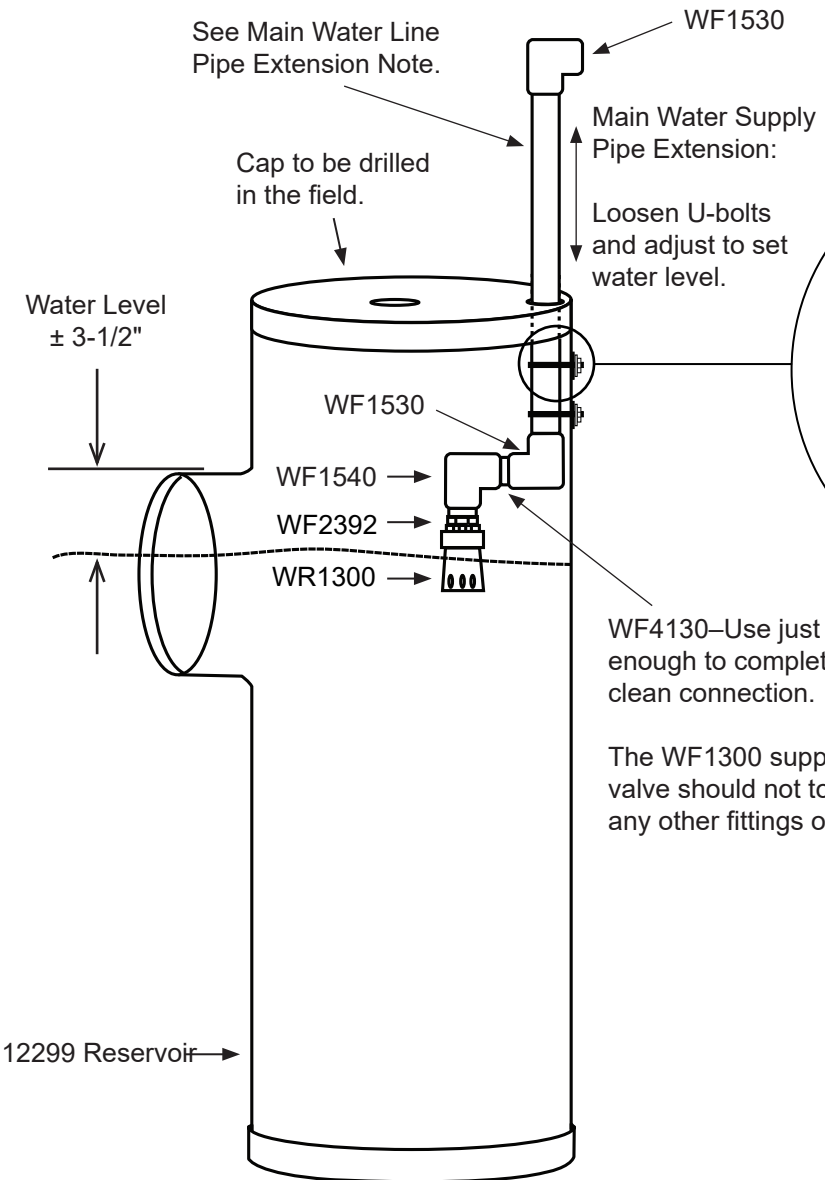

PVC CEMENT AND PIPE TAPE:
 Except for the supply header-to-coupler connections, prime and cement all socket joints using pvc primer and cement during assembly.

 Apply a couple of layers of pipe tape to all threaded connections during assembly. Tighten fitting until snug.

MAIN WATER SUPPLY PIPE EXTENSION: Cut this pipe from the WF4130 pvc pipe sent with the kit. Length must allow for adjustment of the water valve (up or down) once the main water line is attached and water is turned on.

MINIMUM LENGTH OF PIPE EXTENSION: 36".

Valve assembly can be positioned against the cooling system frame or wall to provide an additional surface to secure the extension pipe.

If desired, use a temporary flexible water line such as a garden house to allow for easier height adjustment during the setup stage. Main water line can be attached later once the water level is set.

Customer supplies additional fittings and pipe to connect the WF1530 elbow to the main water supply.

WF4130—Use just enough to complete a clean connection.

The WF1300 supply valve should not touch any other fittings or pipe.

System Maintenance: Water Screen and Reservoir

Flush and Clean Reservoir

Periodic reservoir maintenance is needed to extend pump life and to prevent dirt and sludge buildup in reservoir. By keeping the reservoir lid in place during operation, you can extend the time between required maintenance and cleaning. A harsh environment will result in more frequent cleaning. Complete these steps to clean the reservoir:

1. Turn off the pump and main water supply.
2. Mark current valve setting for Valve A and then close the valve.
3. Connect a hose to the valve below the water screen and run hose into a tank or drain.
4. Open the valve and turn on the water pump.
5. Pump water out of the reservoir then turn the pump off. Do not allow the reservoir to run dry while the pump is turned on.
6. After pumping most of the water from the reservoir, turn the main water supply on and allow water to fill the reservoir up to the drain trough. **Do not fill the drain trough.**
7. Turn the pump back on and allow it to pump the water from the reservoir again.
8. Repeat as needed until the reservoir and water in the reservoir are clean.
9. Turn off the pump, close the WF3300 valve, and remove drain hose.
10. Allow water to fill system to the required level, return Valve A to its original setting, and turn the pump back on to resume system operation.

Clean Water Screen

Clean the 112298 water screen regularly to maintain consistent water flow and pressure. Complete these steps:

1. Turn off the pump and open the WF3300 drain valve to drain water from the line. If desired, connect a garden hose to capture the water.
2. Remove the water screen housing and clean the screen and housing by rinsing in a bucket of water or spraying with water from a low-pressure nozzle.
3. Reassemble the screen, close the water valve, and turn on the water pump to resume normal operation.

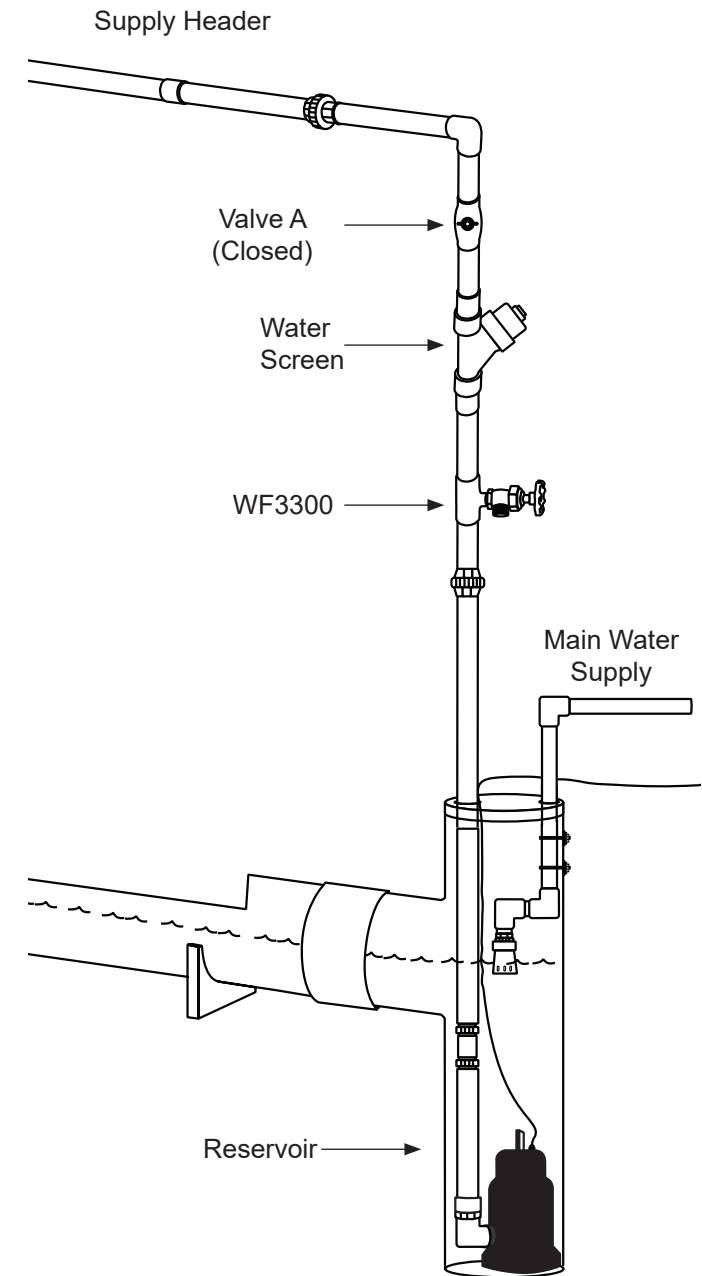

System Maintenance: Supply Header

SUPPLY HEADER MAINTENANCE

The supply header tube must be inspected and cleaned periodically to ensure even and consistent water flow. The presence of dry patches anywhere along the length of the cooling pads may indicate that the supply header is clogged or that spray holes are fully or partially obstructed.

To clean and flush the supply header tubes:

1. With the pump turned on, inspect the spray pattern of the supply header to ensure that water flows from each spray hole.
2. Remove debris and buildup from any spray hole that appears plugged or partially obstructed using a small brush.
3. Fully open Valve B to flush the header tube.
4. Move to Valve A, mark its current setting, and fully open that valve if it is partially closed.
5. Allow water to flow through the system for several minutes.

NOTE: Additional customer-supplied tubing can be added to Valve B to capture water during this process.

6. Reset Valve A to its previous position and close Valve B.

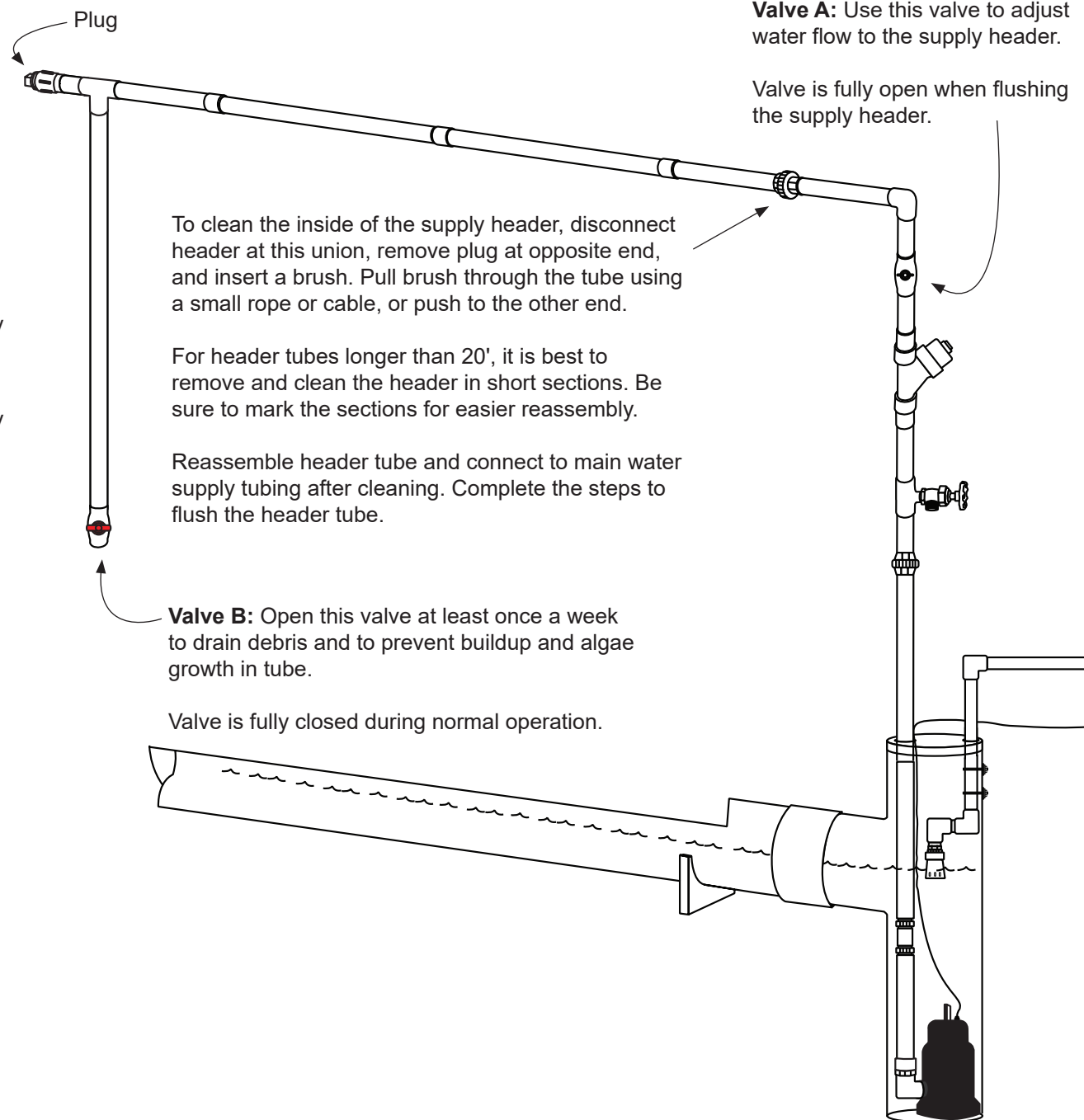

System Maintenance: Cooling Pads & Winterization

Clean Cooling System Pads

Complete these steps:

1. Turn off the fans if possible, or adjust to the lowest setting.
2. Using water sprayed from a garden hose, gently hose off both sides of the pads to remove algae and sediment buildup.

NOTE: To prevent damage, only spray pads with low pressure from a typical garden hose. Do not use a pressure washer! Do not scrub the pads with any tools or cleaning solutions!

Winterizing the Evaporative Cooling System

To shutdown the cooling system throughout the winter, complete these steps to prevent damage to cooling system components:

1. Complete the Flush and Clean Reservoir procedure (Steps 1-7), but do not refill the reservoir.
2. Turn off the main water supply to the system.
3. Remove the water screen and housing and allow to dry. Verify that water screen housing is dry before reassembling.
4. Turn off electricity to water pump and lift pump and supply tube with check valve from reservoir.
5. Disconnect supply tube from pump and allow water to drain from it. To prevent pump and check valve damage, store these items where temperatures remain above freezing.
6. Verify that all evaporative cooling system valves are open and the main water supply is off.
7. Remove the WR1300 main water supply valve and store where temperatures are above freezing.
8. Remove all water from drain trough and reservoir to prevent freezing and damage.



Customer Notes

